

1 List of the many objects (symbols) in the series of papers on Tensor structures by Kazhdan and Lusztig

Here we list in, rough alpha-betical order, the objects (or symbols) used by Kazhdan and Lusztig in their series of paper “Tensor Structures Arising from Affine Lie Algebras, I-IV”, published in the Journal of the American Mathematical Society, 1993-1994.

a-isomorphism (424) a morphism between objects in \mathcal{O}_{κ_0} whose ker and coker are both equivalent to zero

\mathcal{A}_k (section 27.1, p.390), the full subcategory in \mathcal{O} of modules having a Weyl filtration or other projectivity or ext conditions

A (1.1) a commutative algebra with 1

admissible filtration (pp. 391, 404) is a property satisfied by objects in \mathcal{A}_κ

\dot{A} , \dot{A}' (17.2, p.993) are spaces of regular functions on \dot{C} and \dot{C}' respectively

A_∞ , A'_∞ (15.4) are space of regular functions over D and D' respectively

A , \tilde{A} , A' , \tilde{A}' (9.3, p.951;10.3,p.957) are, respectively, spaces of regular functions $\mathbb{C}[\underline{\mathcal{Y}}]$, $\mathbb{C}[\mathcal{Y}]$, $\mathbb{C}[\underline{\mathcal{Y}}']$, $\mathbb{C}[\mathcal{Y}']$

A_0 (10.2, p.957) = $\mathbb{C}[H] = \mathbb{C}[PGL_2(\mathbb{C})] = \mathbb{C}[GL_2(\mathbb{C})]_{\mathbb{C}^*}$, the subalgebra of $\mathbb{C}[GL_2(\mathbb{C})]$ consisting of functions invariant under the scaling action $(g_{ij} \mapsto \lambda g_{ij})$ of \mathbb{C}^* .

(a_{ij}) (19.1) a Cartan matrix

α_i (19.1) simple roots

A (19.1, p.336) = $\mathbb{C}[[\varpi]]$

\mathfrak{A} (19.1) the universal envelope of \mathfrak{g}

A_{V_1, V_2, V_3} (19.10, p.340, 339) the associativity isomorphism

$$R(t_{12}, t_{23}) : V_1 \otimes V_2 \otimes V_3 \rightarrow V_1 \otimes V_2 \otimes V_3$$

\mathcal{A}_κ (§27, p.388) is the subcategory of \mathcal{O}_κ consisting of modules with Weyl filtrations

\mathcal{A}_κ^t (391) is defined as $\mathcal{A}_\kappa \cap \mathcal{O}_\kappa^t$

\mathfrak{s}_a^κ (393) is defined as the nonzero morphism $\mathbf{V}_a^\kappa \rightarrow D(\mathbf{V}_{\hat{a}}^\kappa)$ defined by s_a^κ (Lem.2.32 (c)).

\mathcal{A}_φ (401) a subcategory of \mathcal{O}_φ .

$$\alpha(\kappa) = \varphi(\kappa) \circ \beta(\kappa)$$

α (406, §30) is defined as $q_V \circ p_V$ where $V \in \mathcal{O}_\kappa$, $p_V : \mathcal{F}(V) \rightarrow V$ and $q_V : V \rightarrow \mathcal{G}(V)$

a (407, §31) associativity isomorphism for $(V_1 \dot{\otimes} V_2) \dot{\otimes} V_3$, defined as in §18.2, for objects V 's in \mathcal{A} .

\hat{a} (407, §30) associativity isomorphism for fusion tensor products of objects in \mathcal{O}_∞ .

A_{an} (407, §30) ring of R_∞ -valued analytic germs at $0 \in \mathbb{C}$

a_0, a_1 (409) linear isomorphisms from $\langle \mathcal{N} \rangle \rightarrow \mathcal{N}$ given by the asymptotics

$$a_0(n(t)) = \lim_{t \rightarrow 0} (t^{\Omega_{12}/\kappa} n(t));$$

$$a_1(n(t)) = \lim_{t \rightarrow 1} ((1-t)^{\Omega_{23}/\kappa} n(t)).$$

It turns out that (corollary, p.409) $a^\infty = a_1 \circ a_0^{-1}$.

A (433) is defined as $\mathbb{C}[v, v^{-1}]$

B (8.1, p.942) a commutative \mathbb{C} -algebra with 1, as an alternative base ring to \mathbb{C}

B, B' (9.7, p.952) B is a \mathbb{C} -algebra with a \mathbb{C} -homomorphism $A \rightarrow B$; $B' := B \otimes_A A'$.

B_1 (9.13, p.954) another ring, for studying the base change of Y_{Δ_B}

B_∞, B'_∞ (15.13, p.980) $B_\infty = \mathbb{C}[t]$ and $B'_\infty = \mathbb{C}[t, p, q]/(pq - t)$

B_n, B'_n (15.13) $B_n = B_\infty/(t^n)$, and $B'_n = B'_\infty/(t^n)$

(b_{ij}) (19.1) inverse of Cartan matrix (a_{ij})

B_{V_1, V_2, V_3, V_4} (**or** B') (19.10, p.340) are maps from $(V_1 \otimes V_2) \otimes (V_3 \otimes V_4)$ to $V_1 \otimes (V_2 \otimes V_3) \otimes V_4$; with the target tensor product associated in the two possible ways.

$\nabla(b), \Delta(b), \mathcal{F}(\Delta)$ (pp.390-391) are, respectively, A -modules and category defined in C.M.Ringel, *The category of modules with good filtrations over a quasi-hereditary algebra has almostsplit sequences*, Math. Z. 208 (1991), pp. 209-223

$\beta(\kappa)$ (404) is a morphism: $M(\kappa) \rightarrow M_1(\kappa)$ such that

B (405)

$\beta(V_1, V_2)$ (407) is an isomorphism $\mathfrak{g}(V_1) \otimes \mathfrak{g}(V_2) \rightarrow \mathfrak{g}(V_2 \dot{\otimes} V_2)$ where V_1, V_2 are Weyl modules; It defines an isomorphism between functors θ_1, θ_2 .

$\tilde{\beta}$ (407) is an isomorphism: $\tilde{W}_1 \dot{\otimes} \tilde{W}_2 \xrightarrow{\sim} (W_1 \tilde{\otimes} W_2)^\kappa$, where $W_1, W_2 \in \mathcal{D}$

$(b), (b^*)$ (435) dual bases of \mathfrak{f}_ν

\dot{C}, \dot{C}' (17.1, p.992) are, respectively, the Riemann sphere with three points 0, 1, and ∞ removed, and the variety of (punctured) quadrics $\{(t, p, q) \in \mathbb{C}^3 | pq = t; p, q \neq 1\}$ over it

$\chi^t(V, a)$ (p.396) is the alternating sum $\sum_{i \in \mathbb{N}} (-1)^i \cdot \dim Ext_{\mathcal{O}_\kappa}^i(V, D(\mathbf{V}_a^\kappa))$

$\mathcal{E}, \mathcal{E}^+, \mathcal{E}^0$ (3.7, p.932) are abelian categories, with objects complex-vector spaces V with a given decomposition $V = \bigoplus_{\lambda \in \mathbb{C}} (\lambda V)$, and $\tilde{\mathfrak{g}}$ -module structure (respectively, $\tilde{\mathfrak{g}}^+$ -module and $(\mathfrak{g} \oplus \mathbb{C}\mathbf{1})$ -module structure for \mathcal{E}^+ and \mathcal{E}^0) such that

1. $\epsilon^n c(\lambda V) \subset \lambda_{-n} V$ for all $c \in \mathfrak{g}$ and $n \in \mathbb{Z}$ (respectively, $n \in \mathbb{N}$ and $n = 0$)
2. $\mathbf{1}$ acts as a scalar $\kappa - h$
3. the action of \mathfrak{g} on each piece λV is locally finite (i.e. has finite dimensional orbit on each vector in V)

And irreducible object in \mathcal{C}^- is isomorphic to some $\mathcal{V}_a^\kappa(\lambda)$ where $\lambda \in \mathbb{C}$.

\mathcal{C} is the ring of functions $\frac{B_n[p,q]}{(pq-t)}[(p-1)^{-1}, (q-1)^{-1}]$

C_{V_1, V_2} (19.12) the commutativity isomorphism: $C_{V_1, V_2}(x \otimes y) = e^{i\pi\omega t}(y \otimes x)$, where the exponential is defined as a Taylor series.

$c_i(F)$ (26.4, p.385) is a linear operator: $\bar{Y} \rightarrow Y/\Delta Y : c_i(F)c(x' \otimes x_i \otimes x'') = \pi(x' \otimes (Fc)x_i \otimes x'')$ where $1 \leq i \leq n$ and $F \in A((\epsilon))$.

$C_{a,b,c}$ (393) is defined as $\dim \text{Hom}(\mathcal{V}_a \otimes \mathcal{V}_b \otimes \mathcal{V}_c, \mathbb{C})$

$C_{\bar{a}, b, \bar{c}}$ (429) is defined as $\dim_{\mathbb{C}}(\mathcal{V}_c^\lambda)$

\mathcal{C}_κ (436) is a braided category (of modules over a quantum group)

c_i (438)

\mathcal{D}_0 (p.958) it is the complex vector subspace of $\text{Der}(\tilde{A})$ generated by $\theta_{0,s}$, $\theta_{+1,s}$, $\theta_{-1,s}$ for $s \in S$ (S =the configuration of points on the Riemann sphere)

\mathcal{D}_1 (p.958) it is a subspace of the set of derivations, which commute with the action of H , of the algebra $\tilde{A} = \mathbb{C}[\mathcal{V}]$ on the “lifted” configuration space \mathcal{V} of marked points on the Riemann sphere, so that it maps surjectively $\mathcal{D}_1 \rightarrow \text{Der}(A)$ onto the space of derivations on the moduli space $\underline{\mathcal{V}}$

\mathcal{D}_2 (10.12, p.961) it is the Lie subalgebra of \mathcal{D}_1 consisting of derivations sending the subalgebra $A \subset \tilde{A}$ to zero, i.e. they are derivations along the fibres of the projection $\mathcal{V} \rightarrow \underline{\mathcal{V}}$; It is also an A -Lie algebra: the Lie algebra structure and the A -module structure on \mathcal{D}_2 are compatible. We have (12.11, p.969) $\text{Der}(A) = \mathcal{D}_1/\mathcal{D}_2 \rightarrow \text{End}_{\mathbb{C}}(Y/\Delta Y)$.

D, D' (15.2, p.977) are, respectively, the Riemann sphere with two points 1 and ∞ removed, and the variety of (punctured) quadrics $\{(t, p, q) | pq = t; p, q \neq 1\}$ over it

$\hat{\Delta}_4$ (17.5, p.994) the Lie algebra $\hat{A}' \otimes \mathfrak{g}$

$D(V)$ (1.16) the duality functor of \mathcal{O}_κ defined by $D(V) = {}^dV^\#(\infty)$, where ${}^dV = Hom_A(V, A)$; That is to say, $D(V)$ is the subspace of linear forms $V \rightarrow \mathbb{C}$ having zero values on $Q_{N_i}^\# V$ for some $N_i \neq 1$, with the inherited action of $\hat{\mathfrak{g}}$

$${}^dV \text{ (1.16)} = Hom_A(V, A)$$

Δ (9.9, p.952) is the A -Lie algebra $A' \otimes \mathfrak{g}$ with bracket $[fc, f'c'] = ff'[c, c']$. There is a natural homomorphism of A -Lie algebras $\Delta \rightarrow \hat{\mathfrak{g}}_A^S$ given by $fc \mapsto \sum_{s \in S} \delta_s({}^sfc)$

δ_s (1.6, p.908) is the Lie algebra embedding $\hat{\mathfrak{g}}_A \rightarrow \hat{\mathfrak{g}}_A^S$ extending the simple embedding $\mathfrak{g} \rightarrow \mathfrak{g}^S$

Δ_B (9.9, p.953) is the B -Lie algebra $\Delta_B = B \otimes_A \Delta (= B' \otimes \mathfrak{g})$. There is a homomorphism of B -Lie algebras $\Delta_B \rightarrow B \otimes_A \hat{\mathfrak{g}}_A^S \rightarrow \hat{\mathfrak{g}}_B^S$. There is an exact sequence (9.10(a), p.953)

$$0 \rightarrow B \otimes \mathfrak{g} \xrightarrow{\alpha} \Delta_B \oplus (\hat{\mathfrak{g}}_B^S)^+ \xrightarrow{\alpha'} \hat{\mathfrak{g}}_B^S \rightarrow 0$$

where $(\hat{\mathfrak{g}}_B^S)^+ = B[[\epsilon]]^S \otimes \mathfrak{g}$ (c.f. Lemma 9.8, 9.10)

$Der(A_0)$ (10.2, p.957) The Lie algebra of derivations of A_0 ; It has an A_0 -basis $\{\theta_0, \theta_{-1}, \theta_1\}$ given by the formulae $\theta_{-1} = \theta^{12}, \theta_0 = \theta^{11} = -\theta^{22}, \theta_1 = -\theta^{21}$ where $\frac{\partial}{\partial g_{ij}} = \frac{g_{3-i,3-i}\theta^{ij} - g_{3-i,i}\theta^{3-i,j}}{g_{11}g_{22} - g_{12}g_{21}}$

\mathcal{D}_0 (p.958) it is the complex vector subspace of $Der(\tilde{A})$ generated by $\theta_{0,s}, \theta_{+1,s}, \theta_{-1,s}$ for $s \in S$ (S =the configuration of points on the Riemann sphere)

\mathcal{D}_1 (p.958) it is a subspace of the set of derivations, which commute with the action of H , of the algebra $\tilde{A} = \mathbb{C}[\mathcal{V}]$ on the ‘‘lifted’’ configuration space \mathcal{V} of marked points on the Riemann sphere, so that it maps surjectively $\mathcal{D}_1 \rightarrow Der(A)$ onto the space of derivations on the moduli space $\underline{\mathcal{V}}$

\mathcal{D}_2 (10.12, p.961) it is the Lie subalgebra of \mathcal{D}_1 consisting of derivations sending the subalgebra $A \subset \tilde{A}$ to zero, i.e. they are derivations along the fibres of the projection $\mathcal{V} \rightarrow \underline{\mathcal{V}}$; It is also an A -Lie algebra: the Lie algebra structure and the A -module structure on \mathcal{D}_2 are compatible. We have (12.11, p.969) $Der(A) = \mathcal{D}_1/\mathcal{D}_2 \rightarrow End_{\mathbb{C}}(Y/\Delta Y)$.

δ_i (19.1) symmetrizer, i.e. $(\delta_i a_{ij})$ is a symmetric matrix, it is assumed to be positive-definite

\mathscr{D} (§19, see 19.3,p.337) Drinfeld's category, with as objects free \mathfrak{A} -modules of finite rank over \mathbf{A} ; and as morphisms \mathfrak{A} -linear maps. Its indecomposable objects are V_a where a is in the weight lattice (19.3). There is a structure of tensor category on \mathscr{D} with commutativity (19.12) and associativity (19.10) isomorphisms constructed from (formal) Knizhnik-Zamolodchikov equations (19.8(a)) - see $R(\Pi_0, \Pi_1)$, or A_{V_1, V_2, V_3} (19.10).

\mathscr{D} (26.4) the category of finite dimensional complex vector spaces

$d_m(a)$ (393) is defined as $\dim \mathbf{V}_{a,m}$

$D_{\alpha,m}(a)$ (393) is defined as $\sum_{c \in Y_\alpha(a)} d_m(c)$ when α is a dominant weight; it can be extended (p.393) to the whole weight lattice with the action of the Weyl group

$d_M^K(A, \Lambda)$ (399) is defined as $d_{M(K)}(A_K, \Lambda)$.

δ_a (411) is defined as $\varphi_a = \delta_a Id$, where $\delta_a \in R_\infty$. Its order of pole at κ plays a key role in the numerical criterion of rigidity in Prop. 31.3, p.412.

d_a (412) is defined as δ_a^{-1} . It turns out (31.6, p.413) that $d_a(\kappa) = \frac{v^n - v^{-n}}{v - v^{-1}}$

Δ (416) discriminant function on T

\mathscr{D}_R (421) category of finitely generated R -modules

$d(a, \kappa)$ (430) is defined as $\dim L_a$

e (405) is the natural projection $e : M = M_N \rightarrow M_N/M_{N-1} = \mathbf{1}$; We have $e \circ \tilde{i} = (x - \kappa)^{N-1}$.

$e_{\mathbf{V}_a}$ (412) is a morphism $\mathbf{V}_a^{\hat{\kappa}} \otimes D(\mathbf{V}_a^{\hat{\kappa}}) \rightarrow \mathbf{1}$.

η (423) a morphism: $\mathbf{V}_{a+b-\alpha_i} \rightarrow W$

E_i^V (426)

\bar{E}_i^W (428) defined analogously to E_i^V

$\bar{\mathcal{E}}(\kappa)$ (430) is a category of graded finite-dimensional vector spaces

$E_i^{(p)}$ (436) as an operator $(M^*)^\lambda \rightarrow (M^*)^{\lambda+pi'}$, is defined as:

$$(E_i^{(p)} m^*)(m) = (-1)^p v^{p\lambda(i)+p(p-1)} m^*(E_i^{(p)} m)$$

for $m^* : M^{-\lambda} \rightarrow R, m \in M^{-\lambda+pi'}$

f_s **and** f_s^k (sec. 9.5) $f_s := \frac{1}{\gamma_s^{-1}(z)} \in \mathbb{C}$ is the reciprocal of the value of the local chart of a point z on the projective line $P(1) \cong \mathbb{C}$. The set $\{1, f_s^k (s \in S; k \geq 1)\}$ form a basis of A' over A (Lemma 9.6, p.951)

$^s f$ (9.4) is a homomorphism of A -algebras: $A' \rightarrow A((\epsilon))$, which is an expansion along the extra parameter z of \mathcal{V}' over \mathcal{V} of a regular function $f \in A' = \mathbb{C}[\underline{\mathcal{V}}]$ on the moduli space $\underline{\mathcal{V}}' = H \setminus \mathcal{V}'$ of the Riemann sphere with marked points

F^t (3.3) a finite set $\{a \in \mathbb{N}^I \mid \langle a, a+2 \rangle \leq t\}$ where t is an integer greater than (or equal to?) 1

f_s **and** f_s^k (9.5, p.951) $f_s := \frac{1}{\gamma_s^{-1}(z)} \in \mathbb{C}$ is the reciprocal of the value of the local chart of a point z on the projective line $P(1) \cong \mathbb{C}$. The set $\{1, f_s^k (s \in S; k \geq 1)\}$ form a basis of A' over A (Lemma 9.6, p.951)

ϕ (10.3) is a map: $H \times P^1 \rightarrow P^1$ given by the evaluation $\phi(\gamma, z) = \gamma(z)$. The vector fields θ_k act on the first factor γ , and we have $\theta_k(\phi) = z^{k+1} \frac{\partial \phi}{\partial z}$

$\tilde{f}(z)$ (19.8) is the rescaled function $z^{\varpi \Pi_0} f(z)$ where $f(z)$ is a solution of the formal KZ equation (19.8(a)).

\tilde{f}_n (19.8, p.339) Fourier coefficients of the series expansion of $\tilde{f} = \sum_{n \geq 0} \varpi^n \tilde{f}_n$. It is a function: $(0, 1) \rightarrow {}^0 V$ which extends to the interval $[0, 1)$ (p.339).

$R_0(f), R_1(f)$ (p.339) are two maps from the space \mathcal{X} of solutions of KZ equations (19.8(a)) to the representation space V . $R_0(f)$ is the rescaled asymptotic of f at 0, i.e.

$$R_0(f) = \lim_{z \rightarrow 0} \tilde{f} = \sum_{n \geq 0} \varpi^n \lim_{z \rightarrow 0} \tilde{f}_n(z) \in V.$$

$R_1(f)$ is a similar asymptotic at 1, where f is rescaled by $(1-z)^{-\varpi \Pi_1}$.

f_N (26.3) is defined as the natural map $\hat{W}(-\infty) \rightarrow W/G_N W$.

f_{ij} (26.4) a function on \mathcal{V}

F_κ (404) field of fractions of R_κ

\mathcal{F} (406, §30) is defined as the functor: $V \mapsto V(1)$ from \mathcal{O}_κ to \mathcal{D} , the category of finite dimensional representations of the Lie algebra $\mathfrak{g}_F := \mathfrak{g} \otimes_{\mathbb{C}} F$ where κ is a ring morphism: $R \rightarrow F$ from ring R to a field F .

$F_{a,b}(\kappa)$ (424) is a rational function of Gamma factors

F_i^V (427)

\bar{F}_i^W (428) defined analogously to F_i^V

\mathbf{f} (433) is an algebra over $\mathbb{C}(v)$ with generators $\kappa_i : i \in I$ and relations

$$\sum_{p,p' \in \mathbb{N}; p+p'=1-a_{ij}} (-1)^{p'} \frac{\kappa_i^p}{[p]!} \kappa_j \frac{\kappa_i^{p'}}{[p']!} = 0$$

$\mathbf{A}\mathbf{f}$ (434) is the A-subalgebra of \mathbf{f} generated by the divided powers $\kappa_i^{(p)} = \frac{\kappa_i^p}{[p]!}$

\mathbf{f}_v (434) ???

$R\mathbf{f}$ (434) is an R-algebra defined by a change of scalar; where R is a commutative algebra over A

${}_R\mathcal{C}$ (434) is an abelian category of finitely generated R-modules with action of $R\mathbf{f}$.

$F_i^{(p)}$ (436) is defined analogously to $E_i^{(p)}$

$g_{a,b}$ (20.6(a)): elements in \mathbf{A} , measuring the discrepancy of the S'_c morphism at different weight c 's before and after the action of the morphism $T_{a,b}$

Γ (p.926) is the Lie algebra \mathfrak{g} with coefficients in the ring of regular functions over a genus-zero complex curve with finitely many points removed

γ_s (4.2) is a "chart": $P^1 \rightarrow C$, or, a morphism of varieties from the complex projective line P^1 to a genus zero curve C with a unique marked point $p_s \in \heartsuit$ on every component, such that $\gamma_s(0) = p_s$

Γ (4.6, p.926) is the central extension $\Gamma = (R \otimes \mathfrak{g}) \oplus \mathbb{C}\mathbf{1}$ of the Lie algebra of the Lie-valued regular functions on the algebraic curve C'

G_N (4.8, p.927) the complex subspace of $U(\Gamma)$ spanned by products $(f_1 c_1) \dots (f_N c_N)$ with $f_i \in R_1$ and $c_i \in \mathfrak{g}$.

$g_s(p)$ (7.2, p.938) ,for $s \in [s_0]$, $s_0 \in \heartsuit$, is the regular function in $R = \mathbb{C}[C']$ given by $g_s(p) = \frac{1}{1/\gamma_{s_0}^{-1}(p) - 1/\gamma_{s_0}^{-1}(\gamma_s(0))}$ on the s_0 -component ($p \in C_{s_0}$) and $g_s = 0$ on other components ($p \in C - C_{s_0}$); These functions are introduced in the demonstration (7.3, 7.6) of the finite-dimensionality of $W/G_M W$, which in turn establishes the isomorphisms which state that $T(W)^\#$ and $T'(W)$ are dual to each other under D (Theorem 7.9, p.940). Note that after the definition at [Kazhdan-Lusztig I, p.938, 7.2(a)], the first property of the function g_s should read “ ${}^{s_0}g_s \in \epsilon + \epsilon^2 \mathbb{C}[[\epsilon]]$ ”.

Γ_B (8.2) is the B-Lie algebra $B \otimes \Gamma$, where Γ is the Lie algebra on the algebra of regular functions on the complex curve C' . There is a natural homomorphism: $\Gamma \rightarrow \Gamma_B : x \mapsto 1 \otimes_B x$

\mathfrak{g}' (11.1) = \mathfrak{g}^\clubsuit ; \clubsuit is a finite set

$\gamma_1, \gamma_2, \gamma_{12}, \gamma_3, \gamma_4, \gamma_{34}$ are charts on the complex curve $C = P^1 \sqcup P^1$ sending the points $\{0, 1, \infty\}$ on \mathbb{C} to copies of such on the curve; e.g. $\gamma_1 : P^1 \cong C_{12} : z \mapsto \frac{1}{1-z}$; and also $\gamma_{12} : z \mapsto z$.

\mathfrak{g} (p.335, 19.1) a simple Lie algebra with (a_{ij}) as Cartan matrix

\mathcal{G} (remark following 26.4) the functor $\mathcal{O}_\kappa \rightarrow \mathcal{D} : V \mapsto V/G_1 V$.

$\hat{\mathfrak{g}}$ (400) is defined as $\hat{\mathfrak{g}}_R$

$\hat{\gamma}$ (404) is defined as $x\hat{\beta}^{(n+1)}(m) - \hat{\beta}^{(n+1)}(xm)$

\mathcal{G} (406, §30) is defined as the functor: $V \mapsto V/Q_1^\# V$ from \mathcal{O}_κ to \mathcal{D} , the category of finite dimensional representations of the Lie algebra $\mathfrak{g}_F := \mathfrak{g} \otimes_{\mathbb{C}} F$ where κ is a ring morphism: $R \rightarrow F$ from ring R to a field F . F and G are equivalences of categories; α is a functorial isomorphism between them.

$(\check{\mathcal{G}}, \check{\beta})$ (421) a morphism from the braided category $\check{\mathcal{O}}$ to the Drinfeld category

$\mathcal{G}(\theta)$ (423) an element in $Hom(V_{a+b-\alpha_i}, V_a \otimes V_b) \otimes \check{R}$, the image of $\theta \in \theta_{i;a,b}$.

Hexagon identities (19.13) the two compatibilities of associativity with commutativity in a triple tensor product. They provide solutions for the Yang-Baxter equation.

\mathcal{H} (17.8, p.995) a linear map on the tensor product $\bigotimes_i V_i$ defined by the Sugawara operators: $y_1 \otimes y_2 \otimes y_3 \otimes y_4 \rightarrow y_1 \otimes y_2 \otimes (L_0 - L_{-1})(y_3) \otimes y_4 + y_1 \otimes y_2 \otimes y_3 \otimes (L_0 - L_{-1})(y_4)$; this map lifts the connection map $\nabla_{t\partial/\partial t}$ on the space $\dot{Y}/\dot{\Delta}_4\dot{Y}$ of coinvariants

H (9.1) the group $PGL_2(\mathbb{C})$ of automorphisms of the projective line $P^1 = \mathbb{C} \cup \infty$

$\hat{\mathfrak{g}}^S, \tilde{\mathfrak{g}}^S$ are central extensions of $\mathfrak{g}^S = \overbrace{\mathfrak{g} \oplus \cdots \oplus \mathfrak{g}}^S$, i.e. they have one dimensional centres, and are not direct sums of affine Lie subalgebras

$\mathfrak{h}, \mathfrak{h}^+, \mathfrak{h}'/\mathfrak{h}'^+$ (9.14, p.955) - form a “split induction datum” (A.1, p.1008), e.g. from (9.10(a)), we can take $\mathfrak{h} = (\hat{\mathfrak{g}}_B^S)^+$, $\mathfrak{h}' = \Delta_B$, $\mathfrak{h}'^+ = B \otimes \mathfrak{g}$. This way we can show (proposition 9.15) that the map (9.15(a)) $(B \otimes (\bigotimes_s \mathcal{N}_s))_{\mathfrak{g}} \rightarrow Y_{\Delta_B}$ is surjective and is an isomorphism; We also have the base change behaviour $(B \otimes (\bigotimes_s \mathcal{N}_s))_{\mathfrak{g}} = B \otimes ((\bigotimes_s \mathcal{N}_s)_{\mathfrak{g}})$

\mathcal{H} (17.8, p.995) a linear map on the tensor product $\bigotimes_i V_i$ defined by the Sugawara operators: $y_1 \otimes y_2 \otimes y_3 \otimes y_4 \rightarrow y_1 \otimes y_2 \otimes (L_0 - L_{-1})(y_3) \otimes y_4 + y_1 \otimes y_2 \otimes y_3 \otimes (L_0 - L_{-1})(y_4)$; this map lifts the connection map $\nabla_{t\partial/\partial t}$ on the space $\dot{Y}/\dot{\Delta}_4\dot{Y}$ of coinvariants

$H(V, W)$ (401) is defined as $Hom_{\mathcal{O}}(V, W)$. It is (lemma 29.8) a free R-module of finite rank.

\hat{i} (412)

\bar{i} (19.1) is the label for the corresponding element in the root system for α_i in the involution induced by the longest element w_0 of the Weyl group of \mathfrak{g}

I (19.1) a finite set, to be the set of indices of simple roots

I_n (398) is defined as the set $\{k \in K | kn \in \mathbb{N}\}$

\tilde{i} (406) is a natural embedding: $\mathbf{1} \rightarrow M$ (corollary for lemma 29.12); We have $e \circ \tilde{i} = (x - \kappa)^{N-1}$.

$i_{\mathbf{V}_a}$ (412) is a morphism $\mathbf{1} \rightarrow \mathbf{V}_a^{\hat{\kappa}} \dot{\otimes} D(\mathbf{V}_a^{\hat{\kappa}})$.

i_M (436) is a morphism $\mathbf{1} \rightarrow M \otimes_R M^*$

$j(w)$ (17.23, p.1003) image of an element $w \in T(W)^\#$ in $T(W_n)^\#$, w being represented as a sequence (w_1, w_2, \dots) in $hatW$

j (415) is defined as $e \otimes 1 \otimes e \circ 1 \otimes i \otimes 1$, a morphism from $(\mathbf{V}_a^\kappa)^* \dot{\otimes} \mathbf{V}_a^\kappa \rightarrow T^\kappa \otimes T^{\kappa*}$

\hat{j} (415) is a morphism: $(\mathbf{V}_a^{\hat{\kappa}})^* \otimes \mathbf{V}_a^{\hat{\kappa}} \rightarrow T \otimes T^*$

\tilde{j} (415) is defined as $\hat{j} \otimes F_\kappa$

$\chi^t(V, a)$ (p.396) is the alternating sum $\sum_{i \in \mathbb{N}} (-1)^i \cdot \dim Ext_{\mathcal{O}_\kappa^t}^i(V, D(\mathbf{V}_a^\kappa))$

$l_{ss'}, m_{ss'}, k_{ss'}$ (10.10) they are elements in A ; $l_{ss'}, m_{ss'}$ being the coefficients in the expansion ${}^{s'}f_s = l_{ss'} + m_{ss'}\epsilon + \dots \in A[[\epsilon]]$, where $s \neq s'$; $k_{ss'} \in A'$ is defined by $f_s f_{s'} = l_{ss'} f_{s'} + l_{s's} f_s + k_{ss'} \mathbf{1}$. In fact, $k_{ss'}$ is constant along any fibre of $\underline{\mathcal{Y}}' \rightarrow \underline{\mathcal{Y}}$ and so $k_{ss'} \in A$.

ξ (10.13) is an element $\xi = \sum_{j,s} a_{j,s} \theta_{j,s} \in \mathcal{D}_2$; $a_{j,s} \in A$. The coefficients $a_{0,s}, a_{-1,s}$ satisfy a relation with the coefficients $l_{ss'}$.

$\hat{\kappa}$ (401) the natural embedding $R \rightarrow R_\kappa$

κ_0 (410) is an element in $\mathbb{C} - \mathbb{Q}_{\geq 0}$

κ (430) is a complex number

\mathbf{L}_a^κ (2.8) irreducible quotient of \mathbf{V}_a^κ , where $(a, \kappa - h)$ is the highest weight of the module

L_k (1.14, 1.15) the Sugawara operator, defined by

$$L_k(x) = \frac{1}{2\kappa} \sum_{j \geq -k/2} \sum_p (\epsilon^{-j} c_p)(\epsilon^{j+k} c_p)x + \frac{1}{2\kappa} \sum_{j < -k/2} \sum_p (\epsilon^{j+k} c_p)(\epsilon^{-j} c_p)x$$

where $\{c_p\}$ is an orthonormal basis of \mathfrak{g} ; if it is acting on a tensor product over the set \clubsuit , we denote the action on the t -th factor as $L_{k;t}$; and the total action is $L_k = \sum_{t \in \clubsuit} L_{k;t}$ (1.15)

${}_\lambda V$ (2.23, p.918) subspace of vectors annihilated by some power of $(L_0 - \lambda)$; for example, we have $D(V) = \bigoplus_\lambda {}^d(\lambda V)$, where ${}^d V$ is defined in (1.16)

$l_{ss'}, m_{ss'}, k_{ss'}$ (10.10) they are elements in A ; $l_{ss'}, m_{ss'}$ being the coefficients in the expansion ${}^{s'}f_s = l_{ss'} + m_{ss'}\epsilon + \dots \in A[[\epsilon]]$, where $s \neq s'$; $k_{ss'} \in A'$ is defined by $f_s f_{s'} = l_{ss'} f_{s'} + l_{s's} f_s + k_{ss'} \mathbf{1}$. In fact, $k_{ss'}$ is constant along any fibre of $\underline{\mathcal{Y}}' \rightarrow \underline{\mathcal{Y}}$ and so $k_{ss'} \in A$.

$\Lambda_{\theta_{k,s}}$ (11.2) where $k = 0, +1, -1$; $s \in S$ is defined to be $1 \otimes \dots \otimes L_{k;t} \otimes \dots \otimes 1$; where $L_{k;t}$ is the Sugawara operator L_k acting on \underline{V}_s (p.953) at the s -th position in $Y = \bigotimes_{s \in S} \underline{V}_s$

Λ (11.2) is a complex-linear map: $\mathcal{D}_0 \rightarrow \text{End}_B(Y) : \partial \mapsto \Lambda_\partial$. It is actually (11.2(a)) a homomorphism of Lie algebras over \mathbb{C} .

Λ', Λ'' (11.3) $\Lambda' : \mathcal{D}_1 \rightarrow \text{End}_B(Y)$ is the unique A -linear extension of Λ to \mathcal{D}_1 ; Λ'' is the restriction of Λ' to \mathcal{D}_2 . Λ'' is a homomorphism of A -Lie algebras.

\hat{L}_0 (26.3) is defined as $\varprojlim L_0(N)$.

$\lambda_a(n)$ (393) is defined as $\frac{1}{2\kappa} \langle a, a+2 \rangle + m$

Λ, F, M, A (405) Λ is a ring of formal power series over \mathbb{C} ; F its field of fractions; and M a free finitely generated module over Λ with a filtration $0 = M_0 \subset M_1 \subset \dots \subset M_N = M$ such that the quotients are torsion free; A an endomorphism of M preserving the filtration and such that for every $i : 1 \leq i \leq N$, the quotient modules $\bar{M}_i = M_i/M_{i-1}$ decomposes as $\bar{M}_i = \bigoplus_{j=1}^{n_i} M^{\alpha_j^i}$

$\lambda_{2\rho}$ (411) is defined as $\prod_{i \in I} \lambda_i^{c_i}$

L (415) is defined as $\ker(e_{\mathbf{V}_a^\kappa}) \subset (\mathbf{V}_a^\kappa)^* \otimes \mathbf{V}_a^\kappa$

\hat{L} (415) is defined as $\ker(e_{\mathbf{V}_a^{\hat{\kappa}}}) \subset (\mathbf{V}_a^{\hat{\kappa}})^* \otimes \mathbf{V}_a^{\hat{\kappa}}$

\tilde{L} (415) is defined as $\hat{L} \otimes F_\kappa \subset \ker(\tilde{j})$

\mathcal{L} (436) is an irreducible object in \mathcal{C}_κ

$l_{ss'}, m_{ss'}, k_{ss'}$ (10.10) they are elements in A ; $l_{ss'}, m_{ss'}$ being the coefficients in the expansion $s'f_s = l_{ss'} + m_{ss'}\epsilon + \dots \in A[[\epsilon]]$, where $s \neq s'$; $k_{ss'} \in A'$ is defined by $f_s f_{s'} = l_{ss'} f_{s'} + l_{s's} f_s + k_{ss'} \mathbf{1}$. In fact, $k_{ss'}$ is constant along any fibre of $\underline{\mathcal{Y}}' \rightarrow \underline{\mathcal{Y}}$ and so $k_{ss'} \in A$.

$\mathcal{M}, \dot{\mathcal{M}}$ (17.10) $\mathcal{M} = Y_\infty / \Delta_{4,\infty} Y_\infty$, $\dot{\mathcal{M}} = \dot{Y} / \Delta_4 \dot{Y}$. It is an A_∞ -module and has a natural connection with regular singularity at 0 (17.14, p.998).

$\tau(M)$ (17.24, p.1004) torsion module of M over A_∞ , i.e. vectors annihilated by powers of t .

M^f (17.24) = $M / \tau(M)$

\hat{M} (17.24) = $\varprojlim_{n \geq 1} M / t^n M$

$\hat{\mathbf{M}}$ (17.24, p.1005) = $\text{Hom}_{\mathbb{C}[[t]]}(\hat{\mathcal{M}}'^f, \hat{\mathcal{M}}^f)$

$\mathcal{M}_{an}, \mathcal{M}'_{an}, \mathbf{M}_{an}$ (17.26, p.1005) real analytic bundles on the real interval $(-\infty, 1)$

$M(K)$ (398) is defined as $M \otimes_R K$

${}_\Lambda M^\perp$ (399) is defined as $\bigoplus_{\substack{\Lambda' \in T(A, M) \\ \Lambda \neq \Lambda'}} \Lambda' M$.

$M_i^{(n)}$ (403) is defined as $M_i / (x - \kappa)^n M_i$ where i is equal to 1 or 2.

\check{M} (404) image in \mathcal{O}_κ of any object M in \mathcal{O}_κ

$m_{(i,j)}^Z$ (405), where Z is a subset of Q , is an endomorphism of \check{M} , defined as follows: $\alpha_j^i - \check{B}$ for $(i, j) \notin Z$; and $-\check{C}$ for $(i, j) \in Z$.

M (407) finitely generated torsion-free R_∞ -module

\bar{M}_{an} (407) is defined as $M \otimes_{R_\infty} A_{an}$

m_0 (418) a constant

\tilde{m} (425) morphism defined with the generalised T, S, τ morphisms, in the same way as the "unchecked" morphism in Part III.

$M_{V, V'}$ (426)

$\bar{M}_{W, W'}$ (428) the unique functorial isomorphism $\bar{X}(W) \otimes \bar{X}(W') \rightarrow \bar{X}(W \dot{\otimes} W')$ in \mathcal{O}_κ , satisfying a commutation relation between the M and r morphisms. (429)

\mathcal{N} (2.1) nil-module, that is, a finite-dimensional module over the \mathbb{C} -algebra $\mathbb{C}[\epsilon] \otimes \mathfrak{g}$, and the ideal $\epsilon\mathbb{C}[\epsilon] \otimes \mathfrak{g}$ acts nilpotently on \mathcal{N} , i.e., there exists a fixed number $t > 1$ such that any t elements in $\epsilon\mathbb{C}[\epsilon] \otimes \mathfrak{g}$ acts on \mathcal{N} as zero

\mathcal{N}^κ (2.3) generalized Weyl module induced by the nil-module \mathcal{N}

$M(\kappa)$ (section 29, p.397) is the quotient $M/(x - \kappa)$

\mathbb{N} in the paper, the set of natural numbers is defined as the set of non-negative integers, including zero (?)

ν (4.16, p.931) is a \mathbb{C} -linear map: $T(W) \otimes X \rightarrow (W \otimes X)/G_1(W \otimes X)$, defined canonically; the image $\nu(\tilde{\mathfrak{g}}^\heartsuit(T(W) \otimes X))$ is contained in $\Gamma(W \otimes X)/G_1(W \otimes X)$ (4.17, p.932); Thus we have ¹ an induced canonical map of coinvariants $(T(W) \otimes X)_{\tilde{\mathfrak{g}}^\heartsuit} \rightarrow (W \otimes X)_\Gamma$.

∇ (12.2, p.967) a connection on \mathcal{A} -module M , i.e. a \mathbb{C} -linear map $\nabla : M \rightarrow \Omega_{\mathcal{A}}^1 \otimes_{\mathcal{A}} M$, satisfying the Leibniz condition $\nabla(am) = d(a) \otimes m + a\nabla(m)$ for $a \in \mathcal{A}, m \in M$; where $\Omega_{\mathcal{A}}^1 = \mathcal{I}/\mathcal{I}^2$ is an \mathcal{A} -module and \mathcal{I} is the kernel of the multiplication map $\mathcal{A} \otimes \mathcal{A} \rightarrow \mathcal{A}$. There is an isomorphism $Hom_{\mathcal{A}}(\Omega_{\mathcal{A}}^1, \mathcal{A}) \cong Der(\mathcal{A})$ given by $f \mapsto fd$.

∇_∂ (12.3) is a map in $End_{\mathbb{C}}(M)$; given a derivation $\partial \in Der(\mathcal{A})$, ∇_∂ is given by the composition of ∇ with $\partial \otimes 1_M$:

$$M \rightarrow \Omega_{\mathcal{A}}^1 \otimes_{\mathcal{A}} M \rightarrow \mathcal{A} \otimes_{\mathcal{A}} M \cong M$$

¹ Γ being the Lie algebra \mathfrak{g} tensored with the ring of regular functions over a complex curve, see p.926

$\nabla_{\partial}(m)$ is \mathcal{A} linear in the two variables m and ∂ .

∇^0, ∇^1 (12.7, p.968) they are connections on the A -module Y , with $\nabla_{\partial}^0(fy) = \partial(f)y$ and $\nabla_{\partial}^1 = \nabla^0\pi(\partial) + \Lambda'_{\partial}$, where $\pi : \mathcal{D}_1 \rightarrow Der A$ is the canonical map. $\nabla^1 : \mathcal{D}_1 \rightarrow End_{\mathbb{C}}(Y)$ is a homomorphism of Lie algebras over \mathbb{C} .

∇, ∇' (17.16) are \mathbb{C} -linear maps: $\mathbb{C}[t] \otimes X_{12} \otimes X_{34} \rightarrow \mathbb{C}[t] \otimes X_{12} \otimes X_{34}$ defined by the Sugawara operator $L(0)$. They induce the same complex-linear map $\nabla_{t\partial/\partial t}$ on the space of coinvariants $(\mathbb{C}[t] \otimes X_{12} \otimes X_{34})_{\Delta_{2,\infty}}$, and on this $\mathbb{C}[t]$ -module it defines a connection with regular singularity

ν (17.1) a morphism: $\dot{C} \rightarrow \underline{\mathcal{Y}}$

$$[n]_i \text{ (19.1)} = \frac{v_i^n - v_i^{-n}}{v_i - v_i^{-1}}$$

$\tilde{\nabla}$ (p.387) is defined as $\nabla_0 + \hat{\omega}$.

∇^{tr} (p.387) is the trivial connection on $A_{\infty} \otimes \bar{Y}/\mathfrak{g}\bar{Y}$

$\tilde{\mathcal{N}}$ (392) the U^{κ} -module induced from the $U(\mathfrak{g})$ -module \mathcal{N} .

\mathbb{N}_0 (393) a subset of \mathbb{N}^I , depending on the rationality of κ

$\tilde{\mathcal{N}}$ (401) the object in \mathcal{O}_{φ} corresponding to the nilmodule \mathcal{N} .

$\alpha^{(n)}$ (403) is a morphism $M \rightarrow M_2^{(n)}$ of $\hat{\mathfrak{g}}_{R_{\kappa}}$ -modules (prop.29.3)

N_j (405)

$\nabla_{t\partial/\partial t}^0$ denotes the trivial connection on M_{an}

$\nabla_{t\partial/\partial t}$ (407) a connection on \mathcal{M}_{an}

$\nabla'_{t\partial/\partial t}$ (407) a connection on \mathcal{M}_{an}

$(\mathcal{N}, \nabla_{\partial/\partial t})$ (408) an R -vector bundle over $\mathbb{C} - \langle 0, 1 \rangle$ with connection $\nabla_{\partial/\partial t}$ being (the trivial connection) $+ -\frac{1}{\kappa}(\frac{\Omega_{12}}{t} - \frac{\Omega_{23}}{1-t})dt$

$\langle \mathcal{N} \rangle$ (408) space of flat sections $n(t)$ of $\tilde{\mathcal{N}}$ over the interval $(0, 1)$.

$n_a(\kappa)$ (412) the order of zero of d_a at κ

$\mathbb{N}^I(\theta)$ is defined as $\{a \in \mathbb{N}^I \mid \theta_a|_{Z_{\theta}} \equiv 1\}$

$\tilde{\mathbf{N}}$ (417) is defined as $\{a \in \mathbf{N}^I(\theta) | T_a^\kappa \text{ is projective}\}$

$\bar{\mathbf{N}}$ (417) is defined as the image of $\tilde{\mathbf{N}}$ in $\mathbf{N}^I(\theta)/p\mathbf{N}^I(\theta)$

$\mathbf{N}^I(m)$ (418) a subset

$[n]$ (433) is defined as $\frac{v^n - v^{-n}}{v - v^{-1}}$ for an integer n

$\{\omega_i | i \in I\}$ (19.1) the collection of simple roots

\mathcal{O}_κ (Kazhdan and Lusztig's introduction, p.905) - "category \mathcal{O} ", consisting of modules of finite length over $\hat{\mathfrak{g}}$, with central charge $\kappa - h$, and whose composition factors are irreducible highest weight modules corresponding to weights which are dominant in the \mathfrak{g} -direction (p.905)

\mathcal{O}_κ^t (3.3) a full subcategory of \mathcal{O}_κ whose objects have composition factors \mathbf{L}_a^κ for some a in the set F^t ; it is closed under extension and duality $V \rightarrow D(V)$

$\langle \omega c \rangle$ (4.9, p.927) $\hat{\mathfrak{g}}$ module structure on the completion \hat{W} defined through the approximation property 4.9(a) of the space R of regular functions on C'

ω (6.3, p.934) a collection $(\omega_s)_{s \in \heartsuit} \in \mathbb{C}((\epsilon))^\heartsuit$ of Laurent series ω_s , such that $\omega c \in \hat{\mathfrak{g}}^\heartsuit$ acts on Z^∞ via $\langle \omega c \rangle \lambda = (gc)\lambda$ where $g \in R = \mathbb{C}[C']$ is a regular function on the curve C' which expands, at each point $s \in \heartsuit$, to a series approximating ω to the N -th order, i.e. ${}^s g - \omega_s \in \epsilon^N \mathbb{C}[[\epsilon]]$ for every $s \in \heartsuit$.

ω_n (17.27(a)) an element in $\mathbf{M}/t^n \mathbf{M}$ constructed from an isomorphism of quotients of \mathcal{M} and \mathcal{M}' .

$\tilde{\omega}$ (17.27, 17.28) an analytic section of \mathbf{M}_{an} , horizontal with respect to the connection $\nabla_{t\partial/\partial t}$, which is the analytic continuation along the interval $(-\infty, 1)$ of the power series ω at 0,

ω_i (19.1) fundamental weights

$\Omega^{(2)}$ (26.3) is defined as $\sum_p c_p \otimes c_p \in U(\mathfrak{g}) \otimes U(\mathfrak{g})$

$\hat{\omega}$ (p.387) is defined as $-\frac{1}{\kappa} \left(\sum_{i=1}^n \Omega_i \omega_{i,0} + \sum_{i=1}^n f_{i,j} \Omega_{i,j}^{(2)} \omega_{i,-1} \right)$. Since it commutes with the action of \mathfrak{g} on \hat{Y} , it defines a connection Δ on the bundle $A \otimes \tilde{Y}/\mathfrak{g}\tilde{Y} \cong Y/\Delta Y$. It coincides (cor. 26.1) with the connection defined in §12.11.

$\mathcal{O}_\kappa(z)$ (393) a certain full subcategory of \mathcal{O}_κ where all irreducible subquotients of V are isomorphic to L_a^κ for some $a \in z \cap \mathbb{N}^I$; where $z \in Z$ is a W_κ -orbit on \mathbb{Z}^I .

$\mathcal{O}_\kappa^a, \mathcal{O}_\kappa^{<a}$ (396) are full subcategories of \mathcal{O}_κ with composition factors of some given form, their highest weights being restricted to some subsets

\mathcal{O} (400) the full subcategory of $\tilde{\mathcal{O}}$ of $\hat{\mathfrak{g}}$ modules, consisting of those which are free as R -modules, and for any $\kappa \in S$, the module $V(\kappa)$ belongs to the category \mathcal{O}_κ .

\mathcal{O} (401) is the category of $\hat{\mathfrak{g}}_{\tilde{R}}$ -modules defined analogously to \mathcal{O}

\mathcal{O}_∞ (401) is defined as $\mathcal{O}_{\kappa_\infty}$

\mathcal{O}^a (402) the full subcategory of \mathcal{O} , consisting of modules V such that, for any $\kappa \in S$, $V(\kappa)$ lies in \mathcal{O}_κ^a . (§29.8, §28)

$(\mathcal{O}_\infty, \dot{\otimes}, a, \mathcal{P})$ (410) is a braided category (corollary, p.410); (\mathcal{G}, β) defines an equivalence between \mathcal{O}_∞ and \mathcal{D} (corollary, p.410); where $\beta : \mathcal{G}(\tilde{W}_1) \otimes \mathcal{G}(\tilde{W}_2) \rightarrow \mathcal{G}(\tilde{W}_1 \dot{\otimes} \tilde{W}_2)$ (lemma 30.2, p.407)

Ω_κ (412) the intersection of the W_κ -orbit of 0 with with \mathbb{N}^I .

$\mathcal{O}_\kappa^\theta$ is a subcategory of \mathcal{O}_κ , consisting of modules whose irreducible subquotients are isomorphic to L_a where $a \in \mathbb{N}^I(\theta)$

Pentagon identity (19.11) compatibility of associativity isomorphism with itself in a quadruple tensor product

ϕ (10.3) is a map: $H \times P^1 \rightarrow P^1$ given by the evaluation $\phi(\gamma, z) = \gamma(z)$. The vector fields θ_k act on the first factor γ , and we have $\theta_k(\phi) = z^{k+1} \frac{\partial \phi}{\partial z}$

$p_{n,s'}$ (10.8) n-th coefficient of the series expansion of a function $f \in A'$ at a point $\gamma_{s'}(0)$

P, \bar{P} (14.2) are maps: $V \otimes V' \otimes V'' \rightarrow V' \otimes V \otimes V''$ given by $P(x \otimes y \otimes z) = \tau y \otimes \tau x \otimes \bar{\tau} z$ and $\bar{P}(x \otimes y \otimes z) = \bar{\tau} y \otimes \bar{\tau} x \otimes \tau z$. There are induced isomorphisms of coinvariants (14.5) $(V \otimes V' \otimes V'')_{\Delta_{\mathbb{C}}} \rightarrow (V' \otimes V \otimes V'')_{\Delta_{\mathbb{C}}}$ where \mathbb{C} is an A -algebra via evaluation at a point.

$\mathcal{P}, \bar{\mathcal{P}}$ (14.6(d)) is the transpose $(V \dot{\otimes} V') \rightarrow (V' \dot{\otimes} V)$ in \mathcal{O}_{κ} of the map $D(V' \dot{\otimes} V) \cong D(V \dot{\otimes} V')$ constructed at (14.6(b)). The two maps $\mathcal{P}, \bar{\mathcal{P}}$ are in fact inverse of each other (p.977).

Φ_n (section 15, p.977; 15.24, p.983; 15.25) where $n \geq 1$, is a family of maps relating the two spaces of coinvariants on non-singular and degenerate quadrics (i.e. union of two lines). Φ_n is constructed as a B_n -linear map (15.25(a), p.984): $T(W_n)^{\#}/\Delta_{2,n}T(W_n)^{\#} \rightarrow W_n/\Delta_{4,n}W_n$, where $1 \leq n < \infty$. It is shown in §16 that Φ_n is an isomorphism for every $n \geq 1$. (proposition 15.27, p.985)

Ψ_n (15.20, p.982) is an isomorphism of B_n -modules (15.20(a)):

$$(B_n \otimes (V_1 \dot{\otimes} V_2) \otimes (V_3 \dot{\otimes} V_4))_{\Delta_{2,n}} \cong T(W_n)_{\Delta_{2,n}}^{\#}$$

$P_0, P, \hat{P}_0, \hat{P}$ (16.9) are Lie algebras with coefficients being rational functions or formal power series; e.g. $P = P_0 + B_n \mathbf{1}$ where $P_0 \cong \frac{B_n[p,q]}{pq-t} \otimes \mathfrak{g} \subset \tilde{\mathfrak{g}}_{B_n}^{\heartsuit}$

Π_n (16.17, p.992; 17.23, p.1003) (see 8.5(a), p.994) a map from $\tilde{\mathfrak{g}}_{B_n}^{\heartsuit}$ -coinvariants to Γ -coinvariants. It is compatible (17.23) with the connections $\nabla_{t\partial/\partial t}$.

ϖ (§19) a formal variable, to be thought of as $1/\kappa$.

Π_0, Π_1 (19.8, 19.9, 19.10) endomorphisms of V , in particular, the quadratic commuting element t acting on the 12- or 23- components of $V_1 \otimes V_2 \otimes V_3$.

π (26.4) is defined as the natural projection $Y \rightarrow Y/\Delta Y$

$\varphi(t)$ (387) is defined as $-\frac{q}{\kappa} \left(-\frac{t}{1-t} \Omega_{13}^{(2)} + \Omega_{34} \right)$. Its sum with the trivial connection ∇^{tr} is equal to (Lem.26.6) $\nabla_{t\partial/\partial t}$

φ_t (387) is defined as the map: $\bar{\mathcal{M}}(0) \rightarrow \mathcal{M}(0)$ defined in §15.25, p.984 (???), which can be considered as an endomorphism on $\bar{Y}/\mathfrak{g}\bar{Y}$.

$\mathcal{P}_a^{\kappa}(\lambda)$ (388) is defined as $U(\hat{\mathfrak{g}}^-) \otimes_{U(\mathfrak{g})} \mathcal{V}_a$

φ (401) is some ring homomorphism $R \rightarrow \tilde{R}$

\mathcal{P} (407, §31) commutativity isomorphism for $(V_1 \otimes V_2)$

φ (407, §31) isomorphism $\langle V_1 \dot{\otimes} V_2, V_3 \dot{\otimes} V_4 \rangle \xrightarrow{\sim} \langle V_1, V_2, V_3, V_4 \rangle$ defined as in §17.29 (p.1008), for objects V 's in \mathcal{A} .

\hat{P} (407, §30) commutativity isomorphism for fusion tensor products of objects in \mathcal{O}_∞ .

φ_a (411) is defined as the composition ... , which is a map V_a^∞ to itself. It is part of the "rigidity" structure.

P (412) is the root lattice

P^κ (416) projective module covering the irreducible quotient \mathbf{L}_b^κ .

φ^- (416) an involution of D

φ (421) an embedding $\mathcal{V}_{a+b} \rightarrow \mathcal{V}_a \otimes \mathcal{V}_b$.

$\check{\varphi}_{i;a,b}^e$ (425) morphism defined with the generalised T, S, τ morphisms, in the same way as the "unchecked" morphism in Part III.

$\check{\psi}_{i;a,b}^e$ (425) morphism defined with the generalised T, S, τ morphisms, in the same way as the "unchecked" morphism in Part III.

$\check{\Phi}_{i;a,b}^c$ (426)

$\check{\Psi}_{i;a,b}^c$ (427)

φ_c (429)

φ (431) is a pairing between \mathbf{X}_c and \mathbf{X}_c^* defined via the morphisms M and \check{s}_c .

ψ (432)

$\hat{\psi}$ (432)

P (433) is a polynomial in x, y , with coefficients in the ring of rational functions in \mathbb{C} .

ϕ (435) is a bilinear pairing of X with values in $\frac{1}{c}\mathbb{Z}$

P_{i_ϕ} (435) is defined as $(m \otimes m') \mapsto v^{\phi(\lambda, \lambda')} m \otimes m'$ where the lambda's are weights of the elements m 's

P_γ^κ (438)

Q_k (1.7) is the A-submodule of $U(\tilde{\mathfrak{g}}_A)$ generated by products $(\epsilon c_1) \dots (\epsilon c_k)$, where $c_k \in \mathfrak{g}$

$q_{n,s'}$ (10.8) n-th coefficient of the series expansion of $\theta_{k,s} f$ at a point $\gamma_{s'}(0)$.

Q_N (1.7, p.908)

Q (16.11) a Lie subalgebra of $\tilde{\mathfrak{g}}_{B_n}^\heartsuit$, in which it is the complement of P .

Q (405) is defined as the set of pairs (i, j) such that $1 \leq i \leq N$, $1 \leq j \leq n_i$, and $(i, j) \neq (1, 1)$.

Q_0 (405)

Q_γ^κ (438)

$r_{a,b}$ (10.16(a)): coefficients for the change of basis from $\Theta_{a-b,s}$ to σ_k induced by the isomorphism of the space $H^S \simeq H^S$ given by (γ_s)

R (4.5, p.926) is the algebra of regular complex-valued functions on the algebraic curve C' obtained from removing points $\{p_s | s \in S (= \spadesuit \sqcup \heartsuit)\}$ from the genus-zero curve C

R_n (4.8, p.927) is a subspace of $R = \mathbb{C}[C']$, consisting of those functions which have an n-th order zero (or (-n)-th order pole if n is negative) at every point $s_0 \in \heartsuit$.

$r_{s,s'}$ (Lemma 11.9)

R (15.18, see also 4.5, p.926) algebra of regular functions on the curve with points removed; the case of §15.18, where the curve $C = P^1 \sqcup P^1$ and $S = \{1, 2, 12, 3, 4, 34\}$, we have $R = \mathbb{C}[u, u^{-1}, (1-u)^{-1}] \oplus \mathbb{C}[v, v^{-1}, (1-v)^{-1}]$

$R(\Pi_0, \Pi_1)$ (p.339) is the isomorphism $R_1 \cdot R_0^{-1} : V \rightarrow \mathcal{X} \rightarrow V$

R (397) the ring of analytic functions over an unbounded open subset $S \subset \mathbb{C}$ meromorphic at infinity

R_κ (398) is defined as the completion of R at κ

R (400) is defined as $R_S =$ the ring of analytic functions on S , meromorphic at infinity (p.397)

$r(\kappa)$ (401) is a natural embedding $H(V, W)(\kappa) \rightarrow \text{Hom}_{\mathcal{O}_\kappa}(V(\kappa), W(\kappa))$. (lem.29.8); tensoring with R_κ , we have an isomorphism $r(\hat{\kappa}) : H(V, W) \otimes_R R_\kappa \xrightarrow{\sim} \text{Hom}_{\mathcal{O}_{\hat{\kappa}}}(V \otimes_R R_\kappa, W \otimes_R R_\kappa)$.

R_∞ (407, §31) completion of R at infinity

ρ (411) is the sum of fundamental weights

r (421) a positive rational number, depending on the type of the root system

${}_i R$ (435) is a $\mathbb{C}(v)$ -linear map of \mathbf{f}

$\mathcal{R}_{M', M}$ (435) is defined as $\Theta \circ \Pi_\phi \circ \mathbf{s}$

stable object (432) a V in \mathcal{O}_κ such that for every V' , the map $M_{V, V'}$ of $\bar{\mathbf{X}}(-)$'s is an isomorphism

S_c (20.12): the morphism S'_c normalised by an ‘‘admissible collection’’ (20.11) of coefficients $\{g_a\}$ satisfying some cocycle conditions with the set $\{g_{a,b}\}$ (20.6(a))

S'_c (20.4): a morphism: $V_{\bar{c}} \otimes V_c \rightarrow V_0 \simeq A =$ the ring of formal power series over a variable (which will turn out to be $1/(k + \hbar)$, the level plus the dual coxeter number), whose value at the highest weight vector $x_{\bar{c}} \otimes y_c$ is normalised as 1

s_i (19.1) simple reflections

S (9.1) a finite set of at least two elements

σ_k (10.14) where $k = 0, +1, -1$, is a vector field on H^S obtained from θ_{k, s_0} through left translation by $\gamma_{s_0}^{-1}$ for every H-factor for which $s \neq s_0$, where s_0 has been fixed from the beginning. We have $\sigma_k \in \mathcal{D}_2$. They form an A -basis for \mathcal{D}_2 .

S_a^κ (27.6, p.392) is defined as $\text{Hom}_{\mathcal{O}_\kappa}(\mathbf{V}_a^\kappa, D((V)_a^\kappa))$. It can be considered as a bilinear form $s : \mathcal{V}_a^\kappa \times \mathcal{V}_a^\kappa \rightarrow \mathbb{C}$ (p.393).

S (400) the open set $\mathbb{C} - \mathbb{R}_{\geq 0} \subset \mathbb{C}$

$\hat{s}_a^{\hat{\kappa}}$ (406) is defined as $\hat{s}_a \otimes 1$

$\check{s}_a^{\hat{\kappa}}$ (406) is an isomorphism: $\mathbf{V}_{\check{a}}^{\hat{\kappa}} \rightarrow D(\mathbf{V}_{\check{a}}^{\hat{\kappa}})$ defined by $\hat{s}_a^{\hat{\kappa}}$ when $\mathbf{V}_{\check{a}}^{\hat{\kappa}}$ is irreducible.

$\check{s}_a^{\hat{\kappa}}$ (412) is an isomorphism $\mathbf{V}_{\check{a}}^{\hat{\kappa}} \xrightarrow{\sim} D(\mathbf{V}_{\check{a}}^{\hat{\kappa}})$.

\mathcal{S}_a (420) is defined as $Hom_{\mathcal{O}}(V_{\check{a}}, D(V_a)) = Hom_{\mathcal{O}}(V_{\check{a}} \dot{\otimes} V_a, \mathbf{1})$

\check{s}'_a (421) a generator of the free R -module \mathcal{S}_a ; its choice is fixed in corollary to lemma 33.5.

\check{s}_a (422) choice of \check{s}'_a , such that all $g_{a,b} \equiv 1$.

s_a (425) a choice of generators in \mathcal{S}_a

$s_a(\kappa)$ (429)

\mathbf{s} (435) is the switching map for a tensor product of two modules

tilting module (p.390) is a module in \mathcal{O}_{κ} which is in \mathcal{A}_{κ} (i.e. has a Weyl filtration) and so does its dual $D(M)$

$T_{a,b}$ (20.1): a morphism $V_{a+b} \rightarrow V_a \otimes V_b$ of modules over \mathfrak{g}

t (19.2(c)): $t = (1/2)(\Delta(\Omega) - 1 \otimes \Omega - \Omega \otimes 1)$, a bilinear operator on \mathfrak{g} -modules which commutes with the action of \mathfrak{g}

$T(W)^{\#}$ (sections 4.4, 4.11, p.926, p.930) a construction of the fusion tensor product as a $\tilde{\mathfrak{g}}^{\heartsuit}$ module, from a tensor product $W = \bigotimes_{s \in \spadesuit} V_S$ where V_s is a \mathfrak{g} module and $S = \heartsuit \sqcup \spadesuit$

θ_k (10.2, p.957) vector fields on $H = PGL_2(\mathbb{C})$; where $k = 0, +1, -1$

$\theta_{k,s}$ (10.2) vector fields θ_k acting on the s -th tensor factor in a tensor product

$T'(W)$ (6.3, p.934) is the restriction of Z^{∞} as a $\hat{\mathfrak{g}}^{\heartsuit}$ -module to a $\tilde{\mathfrak{g}}^{\heartsuit}$ -module; there are a $\tilde{\mathfrak{g}}^{\heartsuit}$ dualizing homomorphisms (6.6) $T(W)^{\#} \rightarrow D(T'(W))$ and $T'(W) \rightarrow T(W)^{\#}$ which will turn out to be isomorphisms (Remark 6.8, Theorem 7.9) under some finiteness conditions (Corollary 7.5)

$\theta_0, \theta_{-1}, \theta_1$ (10.2- , pp.957-) vector fields on $GL_2(\mathbb{C})$, i.e. derivations of the algebra $\mathbb{C}[GL_2]$, which preserve the subalgebra $A_0 = \mathbb{C}[PGL_2]$ and hence can be regarded as vector fields on $H = PGL_2$, forming

1. an A_0 -basis of $Der(A_0)$ (10.2);
2. a \mathbb{C} -basis of the Lie algebra of derivations of A_0 commuting with the automorphisms of A_0 induced by left translations in H (10.2);
3. a \mathbb{C} -basis of \mathcal{D}_0 , (Lemma 10.6)
4. an $\tilde{A}(= \mathbb{C}[\mathcal{V}])$ -basis of $Der(\tilde{A})$, (Lemma 10.6)
5. an $A(= \mathbb{C}[\mathcal{U}])$ -basis of \mathcal{D}_1 (Lemma 10.6)

$\Theta_{k,s,\sigma}$ (11.5) is a B -linear map: $Y \rightarrow Y$ defined as

$$1 \otimes 1 \cdots \otimes \underbrace{\left(\sum_n \theta_{k,s}(p_{n,\sigma}) \epsilon^n \hat{c} \right)}_{\sigma\text{-factor}} \otimes \cdots 1 \otimes 1$$

$\tau, \bar{\tau}$ (14.1, p.974) which form parts of the commutativity isomorphisms in the category, are maps $V \rightarrow V$, given by \mathcal{O}_κ given by $\tau = e^{i\pi L_0} e^{L_1}$; $\bar{\tau} = e^{-i\pi L_0} e^{L_1}$

$T(f, c), T'(f, c)$ (lemma 15.23) with $f \in \mathbb{C}[u, (1-u)^{-1}]$ and $c \in \mathfrak{g}$, $T(f, c)$ and $T'(f, c)$ are two B_n -linear maps: $W_n \rightarrow W_n$

t, p, q, u, v (16.1) are variables

T (16.2, p.985) is the subalgebra $B_n[u^{-1}] \oplus B_n[v^{-1}]v^{-1}$ of the algebra $B[u, u^{-1}] \oplus B[v, v^{-1}]$.

$\tau(M)$ (17.24, p.1004) torsion module of M over A_∞ , i.e. vectors annihilated by powers of t .

t (19.2) is an element in $\mathfrak{g} \otimes \mathfrak{g}$ which commutes with every Lie-like element $(1 \otimes x + x \otimes 1)$; Under the multiplication map it is mapped into the quadratic Casimir element $\Omega \in \mathfrak{A}$; we have $t = (1/2)(\Delta(\Omega) - 1 \otimes \Omega - \Omega \otimes 1)$

θ, θ_i (19.4) is a map: $V \rightarrow V$ defined, for $x \in V^\lambda$, as

$$\theta_i(x) = \sum_{p,q,r \in \mathbb{N}; p-q+r=\lambda(i)} \frac{(-1)^q}{p!q!r!} f_i^p e_i^q f_i^r x$$

Given a choice of reduced expression of $w_0 = s_{i_1} \dots s_{i_N}$, we can define the operator $\theta = \theta_{i_1} \dots \theta_{i_N}$ which is an isomorphism of V , independent of the choice of reduced expressions. We also have $\theta(f_i x) = -e_i \theta(x)$. θ acts on a tensor product as $\theta \otimes \theta$.

$T_{a,b}$ (20.1): the unique morphism $V_{a+b} \rightarrow V_a \otimes V_b$ of modules over \mathfrak{g} , mapping the highest weight vector to the highest weight vector



TT-identity (20.2) the associativity of the morphism $T_{a,b}$ with itself in an iteration

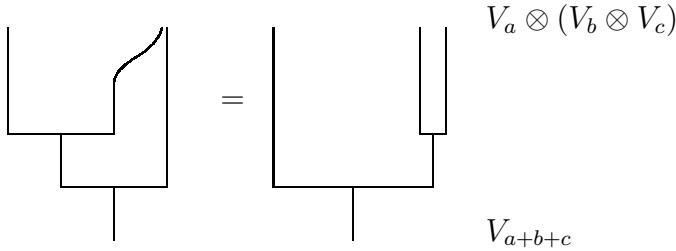

TC-identity (20.3) the compatibility between the T morphism of tensor products $V_{a+b} \rightarrow V_a \otimes V_b$ and the commutativity isomorphism C_{V_1, V_2} .

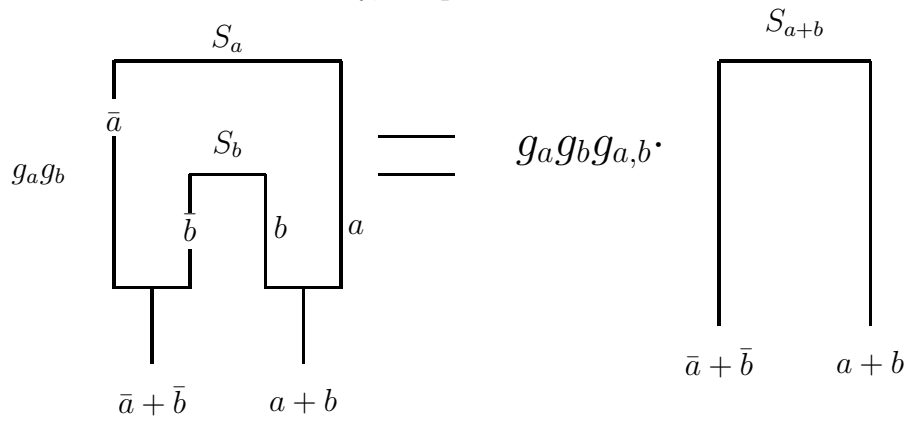
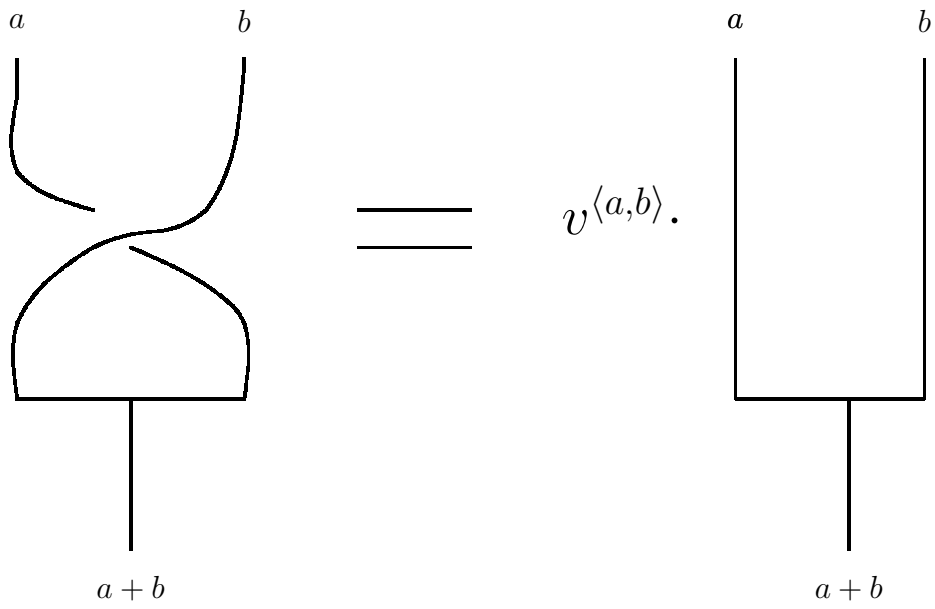

Morphism $tr_{a,b}^c$, §21.1

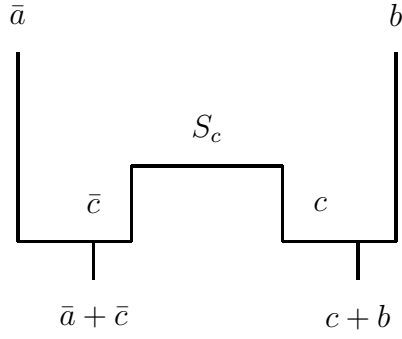

Transitivity of tr , Prop.21.3

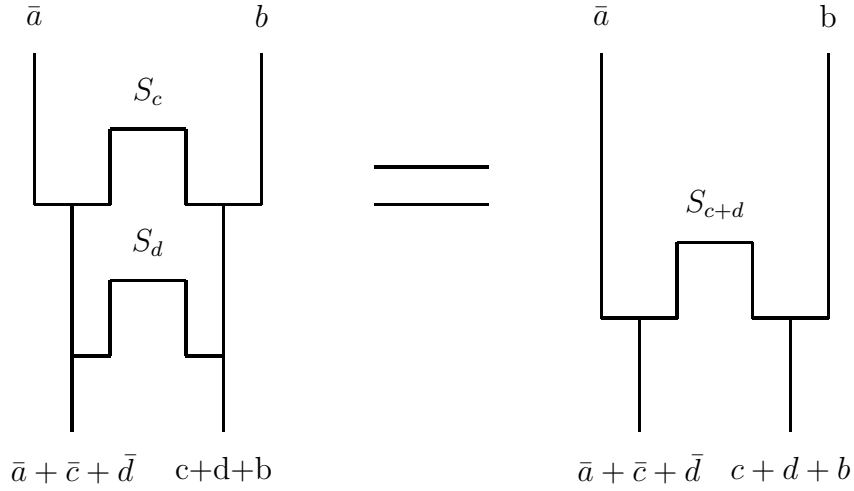

T_0 (26.5) is defined as the submodule of \hat{L}_O -finite vectors in \hat{W} .

θ_1, θ_2 (407) are two functors from $\mathcal{O}_\kappa \times \mathcal{O}_\kappa$ to \mathcal{D} , taking, respectively, a pair of objects to the tensor product of its target by the functor \mathcal{G} and to the target of the fusion tensor product of the pair.

τ (411) is defined as $\lambda_{2\rho}(v)$, an R_∞ -point in G ; where $v = e^{-\pi i/\kappa}$

T (415) lifting (prop.29.2) of T^κ to category $\mathcal{O}_{\hat{\kappa}}$

θ (415) is defined as θ_c which is the character of $Z \in G$ (§31, p.411): $\rho_c(z) = \theta_c(z) \cdot Id$

$\mathcal{T}_{a,b}$ (420) is defined as $Hom_{\mathcal{O}}(\mathbf{V}_{a+b}, \mathbf{V}_a \dot{\otimes} \mathbf{V}_b)$

\check{T} (420) a generator of $\mathcal{T}_{a,b}$

$t_{a,b}$ (421) a fixed element in $\mathcal{T}_{a,b}$

$\theta_{i,a,b}$ (423) is defined as $Hom_{\check{\mathcal{G}}}(V_{a+b-\alpha_i}, V_a \otimes V_b) \otimes \check{R}$

$\tau_{i,a,b}$ an element in $Hom(V_{a+b-\alpha_i}, V_a \otimes V_b) \otimes \check{R}$, defined as a quotient of τ' by Gamma functions

$\check{\tau}_{i,a,b}$ (423) an element in $\theta_{i,a,b}$, mapping to τ (p.423), it exists by prop. 33.1

$\check{t}r_{a,b}^c$ (425) morphism defined with the generalised T, S, τ morphisms, in the same way as the "unchecked" morphism in Part III.

T_ν (435) is an element in ${}_A\mathbf{f}_\nu \otimes_A ({}_A\mathbf{f}_\nu)$, defined with the dual bases b, b^* of \mathbf{f}_ν .

Θ (435) is a morphism for the tensor product of two modules, defined with the maps T_ν

vector field (10.1, p.956) on a smooth variety X is an element in the Lie algebra $Der\mathbb{C}[X]$.

V_a (19.3) highest weight module of \mathfrak{g}

$V(\infty)$ (section 1.9) the collection of smooth vectors in \mathfrak{g} -module V , i.e. those vectors killed by any product $(\epsilon c_1) \dots (\epsilon c_k)$ of a fixed number k of elements of the form ϵc in $A((\epsilon)) \otimes \mathfrak{g} \subset U(\check{\mathfrak{g}}_A)$ (p.909)

\mathbf{V}_a^κ (2.4) Weyl module induced by the irreducible module \mathcal{V}_a

$[V]$ (p.396) $\sum_{a \in F^t} \chi^t(V, a) \cdot [\mathbf{V}_a^\kappa]$

$\mathcal{V} = H \setminus \mathcal{V}$ (sec.9.2) moduli space of complex curves of genus zero with marked points and fixed local charts (which can be extended almost everywhere) at the marked points

\underline{V}_s (8.3) where $s \in \spadesuit$, is a collection of $\check{\mathfrak{g}}_B$ modules with the same central charge $\kappa - h$

\mathcal{V} (9.1, p.950) the open subset of $H^S = \overbrace{H \times \dots \times H}^S$, to be pictured as the configuration space of charts $\mathbb{C} \rightarrow P^1$ with distinct targets for their

origins $0 \in \mathbb{C}$, or, configuration space of a collection S of points in P^1 , each point being accompanied by a local chart

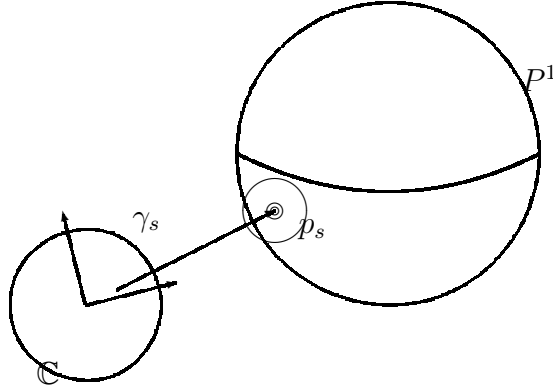

\mathcal{V}' (9.1) a configuration space similar to \mathcal{V} , but with an extra point added, without an accompanying chart, i.e. \mathcal{V}' is an open subset in $H^S \times P^1$.

$\underline{\mathcal{V}}$, $\underline{\mathcal{V}'}$ (9.2) quotients of, respectively, \mathcal{V} and \mathcal{V}' by the left action of $H = PGL_2(\mathbb{C})$

\underline{V}_s (9.11, p.953) a smooth $\tilde{\mathfrak{g}}_B$ -module with central charge $\kappa - h$

$\underline{\mathcal{V}}_0$ (13.1) is a contractible real analytic subset of $\underline{\mathcal{V}}$

v (19.1) $= e^{i\pi\varpi} \in A$

v_i (19.1) $= v^{\delta_i}$

V_a (19.3, p.337) finite dimensional irreducible module of highest weight a

0V (19.8) a vector subspace in V such that $V = {}^0V \otimes_{\mathbb{C}} \mathbf{A}$.

V_+ (Section 26, p.384) is defined as $Q_1^\# V$

V_0 (section 26) is the $\tilde{\mathfrak{g}}^+$ -invariant subspace of V such that $V = V_+ + V_0$

$\beta(V_1, V_2)$ (remark after 26.4) is the natural transformation (isomorphism)
 $\mathcal{G}(V_1) \otimes \mathcal{G}(V_2) \rightarrow \mathcal{G}(V_1 \dot{\otimes} V_2)$

V_i (26.4) is defined as Weyl modules $\mathbf{V}_{a_i}^\kappa$

$\mathbf{V}_{a,m}$ (393) is defined as $\lambda_a(m) \mathbf{V}_a^\kappa$

$\mathbf{V}_a^{\hat{\kappa}}$ (406) is defined as $\mathbf{V}_a \otimes_R R_\kappa$ (remark after corollary to lemma 29.12)

\bar{V}_i (414) quotient of two successive objects V_i in a composition series

\mathbf{V}^N is defined as $(V_c^\kappa)^{\otimes N}$

\mathbf{V}_a (421)

\check{V} (421)

$V \sim_a 0$ (424) a-equivalence; V is a-equivalent to zero if $\text{Hom}_{\mathcal{O}_{\kappa_0}}(V_{\bar{a}-\bar{\alpha}_i}^{\kappa_0}, V) = \langle 0 \rangle$.

$V^{(a,b)}$ (425) is defined as $\text{Hom}_{\mathcal{O}}(V_a \dot{\otimes} V_b, V)$

\check{v}_i (427) is an automorphism of the functor \mathbf{X}

\mathcal{V}_c^λ (429) is defined as $\{v \in \mathcal{V}_c | h_i v = \lambda(i)v; i \in I\}$

W (4.4, p.926) = $\bigotimes_{s \in \blacklozenge} V_s$, where V_s are $\tilde{\mathfrak{g}}$ modules, with a natural filtration coming from the filtration of $U(\Gamma)$

\hat{W} (4.8, p.927) the projective limit of the system of vector spaces $W/G_1W \leftarrow W/G_2W \leftarrow W/G_3W \leftarrow \dots$ induced by the decreasing filtration $W \supset G_1W \supset G_2W \supset \dots$

W_1 (7.4) = $\bigotimes_{s \in \blacklozenge} V_s(N_s)$ where the $N_s \geq 1$ (7.1, p.938) are integers such that $V_s(N_s)$ are finite-dimensional and generate V_s over $\tilde{\mathfrak{g}}$ (Theorem 2.22, p.918); This vector space is introduced in the demonstration of the finite-dimensionality of the quotient W/G_MW .

\underline{W} (8.3, p.943) is the tensor product $\bigotimes_{s \in \blacklozenge} V_s$ over B ; It has a structure of a $\hat{\mathfrak{g}}_B$ module and hence a structure of a Γ_B module via the homomorphism $\Gamma_B \rightarrow \hat{\mathfrak{g}}_B^\heartsuit$ (8.2(b); c.f. 4.6(a), p.926)

\underline{W} (8.3) is the projective limit $\varprojlim_N W/G_NW$

W_n, \hat{W}_n, \hat{W} (15.19) for $W = \bigotimes_{i=1}^4 V_i$, we have: $W_n = B_n \otimes W$; and $\hat{W}_n = \varprojlim_N W_N/G_N W_n$; and $\hat{W} = \varprojlim_N W/G_N W$

W (19.1) the Weyl group, i.e. the finite subgroup of $Aut(\mathbb{Z}^I)$ generated by the reflections $s_i : s_i(\omega_j) = \omega_j - \delta_{ij}\alpha_i$ for $j \in I$.

w_0 (19.1) longest element of the Weyl group; $w_0(\omega_i) = -\omega_i$ for every $i \in I$.

W (393) the Weyl group for \mathfrak{g}

W_κ (393) a certain subgroup of the group of affine automorphisms of \mathbb{Z}^I , depending on the rationality of κ

\tilde{W} (412) is defined as the semidirect product $W \rtimes P$, the affine Weyl group

W_κ (412) a subgroup of the affine Weyl group, depending on the rationality of κ

$W^{(a,b)}$ (428) is defined as the complex vector space $Hom_{\mathcal{O}_\kappa}(V_a^\kappa \dot{\otimes} V_b^\kappa, W)$.

$\tilde{\mathbf{X}}$ (p.438, theorem 38.1) a braided functor giving the equivalence of categories $\mathcal{O}_\kappa \rightarrow \mathcal{C}_\kappa$

X_N (7.3) the complex subspace of $U(\Gamma)$ spanned by the products $(g(s_1)c_1)(g(s_2)c_2) \dots (g(s_N)c_N)$ with $c_i \in \mathfrak{g}$ and $s_i \in \heartsuit$. We have $X_N \subset G_N$.

X (Theorem 7.9) is a smooth $\tilde{\mathfrak{g}}^\heartsuit$ module where $\mathbf{1}$ acts as the scalar $\kappa - h$

\underline{X} (8.5) is a smooth $\tilde{\mathfrak{g}}_B^\heartsuit$ module where $\mathbf{1}$ acts as the scalar $\kappa - h$

ξ (10.13) is an element $\xi = \sum_{j,s} a_{j,s} \theta_{j,s} \in \mathcal{D}_2$; $a_{j,s} \in A$. The coefficients $a_{0,s}, a_{-1,s}$ satisfy a relation with the coefficients $l_{ss'}$.

X_{12}, X_{34} are tensor products $V_1 \dot{\otimes} V_2$ and $V_3 \dot{\otimes} V_4$ respectively

X_n (16.10, p.989) Beilinson's "diagonal module" $X_n = U(\tilde{\mathfrak{g}}_{B_n}^\heartsuit) \otimes_{U(P)} B_n$

x_a (19.4) $= \theta(y_a)$. It satisfies relations $f_i(x_a) = 0$ and $h_i(x_a) = -\bar{a}(i)x_a$.

\mathcal{X} (19.8, p.338) space of analytic (in the sense of §19.8, p.338) solutions on the interval $(0, 1)$ with values in vector space V of the (formal KZ) equation $\frac{df}{dz} = \frac{\varpi_{\Pi_0} f}{z} + \frac{\varpi_{\Pi_1} f}{z-1}$ (19.8(a)).

$\mathbf{X}_\lambda(V)$ (426) is defined as $\varinjlim_{b-a=\lambda} V^{(a,b)}$

$\mathbf{X}(V)$ (426) is defined as $\bigoplus_{\lambda \in \mathbb{Z}^I} \mathbf{X}_\lambda(V)$

$\bar{\mathbf{X}}_\lambda(W)$ (428) is defined as $\varinjlim_{b-a=\lambda} W^{(a,b)}$

$\bar{\mathbf{X}}(W)$ (428) is defined as $\bigoplus_{\lambda \in \mathbb{Z}^I} \bar{\mathbf{X}}_\lambda(W)$

x_c^0 (429) is an element in $(V_{\bar{c}}^\kappa)^{(c,0)}$

$\mathbf{X}(V)(\kappa)$ (432) is defined as $\mathbf{X}(V)/m_\kappa \mathbf{X}(V)$

$\tilde{\mathbf{X}}$ (437) is the functor

$$W \longrightarrow \tilde{\mathbf{X}} = \left(\bar{\mathbf{X}}(W) = \bigoplus_{\lambda} \bar{\mathbf{X}}_\lambda(W), (\bar{E}_i^W)^{(n)}, (\bar{F}_i^W)^{(n)} \right)$$

(see corollary to prop. 36.1). The pair $\tilde{\mathbf{X}} = (\bar{\mathbf{X}}, \bar{M})$ is a braided functor: $\mathcal{O}_\kappa \rightarrow \bar{\mathcal{C}}_\kappa$ (lemma 38.1, p.437). It turns out to be an equivalence of categories (Theorem 38.1, p.438).

Y (9.11, p.953) = $\bigotimes_{s \in S} V_s$

Y_{Δ_B} (9.11) the space of coinvariants $Y/\Delta_B Y$

Y_n (15.10, p.979) = $A_n \otimes \left(\bigotimes_{i=1}^4 V_i \right)$, a $\hat{\mathfrak{g}}_{A_n}^S$ -module and hence a $\Delta_{4,n}$ -module

y_a (19.3) highest weight vector of V_a ; we have $e_i y_a = 0, h_i y_a = a(i) y_a$.

\bar{Y} (26.4) is defined as $\bigotimes_i \mathcal{V}_{a_i}$

Y (26.4) is defined as $\bigotimes_i \mathbf{V}_{a_i}^\kappa$

y_c^0 (429) is an element in $(V_{\bar{c}}^\kappa)^{(0,c)}$

\mathbf{X}_c (431) is defined as $\bar{\mathbf{X}}_c(V_c^\kappa)$

\mathbf{X}_c^* (431) is defined as the object $\bar{\mathbf{X}}_c((V_c^\kappa)^*)$ in $\bar{\mathcal{C}}_\kappa$

- Z (section 6) is the vector space $Z = Hom_{\mathbb{C}}(W, \mathbb{C})$
- Z (6.2) is the space of linear forms $Hom_{\mathbb{C}}(W, \mathbb{C})$, with the action of Γ from W
- Z^N (6.2, p.934) annihilator of $G_N W$, i.e. $Z^N = \{\lambda \in Z | (\forall \xi \in G_N) \xi \lambda = 0\}$
- Z^∞ (6.2) the union of all Z^N , i.e. the inductive limit of $Z^1 \subset Z^2 \subset Z^3 \subset \dots$
- Z (393) set of W_κ orbits on the weight lattice \mathbb{Z}^l .
- Z_r (421) a right-infinite subset of the real line
- ζ (436) is defined as $exp(-i\pi/\delta\kappa)$
- $\dot{\otimes}$ (section 13.4, p.972, 973, etc) the fusion tensor product (sections 4-7, section 13.4, see also part IV), which is the tensor product structure in the category \mathcal{O}_κ of modules over an affine Lie algebra \mathfrak{g} with level $\kappa - \check{h}$
- $\#$ (1.5) the involution of the affine Lie algebra $\tilde{\mathfrak{g}}_A$ given by $(\epsilon^n c)^\# := (-\epsilon)^{-n} c$ and $(\mathbf{1})^\# := -\mathbf{1}$
- $[V]$ (p.396) $\sum_{a \in F^t} \chi^t(V, a) \cdot [\mathbf{V}_a^\kappa]$
- $\langle V_1, V_2 \rangle$ (2.32, p.921) $= (V_1 \otimes V_2) / \tilde{\mathfrak{g}}(V_1 \otimes V_2)$, the \mathbb{C} -vector space of coinvariants of $\tilde{\mathfrak{g}}$ modules V_1 and V_2 . There is an isomorphism (2.32(c))
- $$Hom_{\mathcal{O}_\kappa}(V_1, D(V_2)) \cong Hom_{\mathbb{C}}(\langle V_1, V_2 \rangle, \mathbb{C}).$$
- $\langle V_1, V_2, \dots, V_r \rangle = \mathcal{S}(E)$ (13.3, p.971) space of horizontal analytic sections in the A -module bundle $Y/\Delta Y$ of coinvariants over the moduli space $\underline{\mathcal{Y}}$ with a natural connection given by Sugawara operators (sections 11,12)
- $\clubsuit, \spadesuit, \heartsuit$ (4.2,p.925) are sets of points on the genus zero complex curve under discussion; in particular, there is just one point $s \in \heartsuit$ on each component of the curve, and there are at least two points (denoted $[s]$) from \spadesuit on each component; these $\{[s] \mid s \in \heartsuit\}$ partition the set \spadesuit
- $[V : \mathbf{L}_{a'}^\kappa]$ (3.9, p.924) the number of subquotients isomorphic to $\mathbf{L}_{a'}^\kappa$ in the composition series of V

[12] is the set $\{1,2,12\}$.

$\langle \rangle$ (19.1) pairing in the weight lattice: $\langle a, b \rangle = \sum_{i,j} \delta_{ij} b_{ij} a(i) b(j)$

$$[n]_i \text{ (19.1)} = \frac{v^n - v_i^{-n}}{v_i - v_i^{-1}}$$

$[n]$ (433) is defined as $\frac{v^n - v^{-n}}{v - v^{-1}}$ for an integer n

$(,)$ (435) is a bilinear form on \mathbf{f}

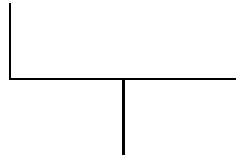

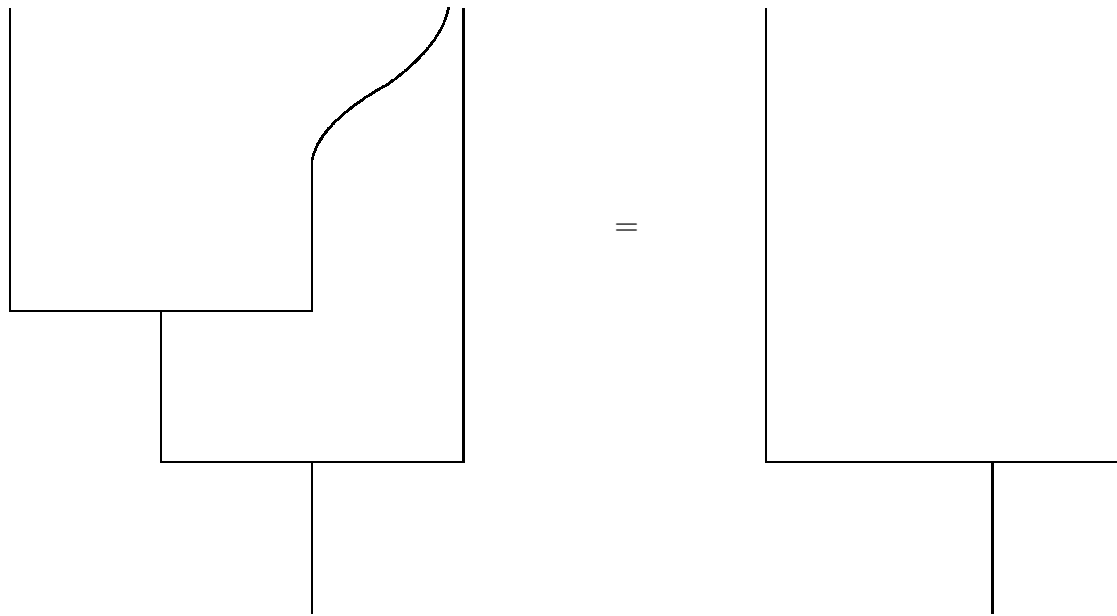
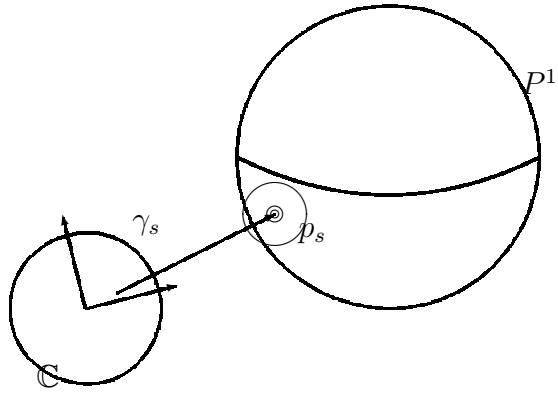

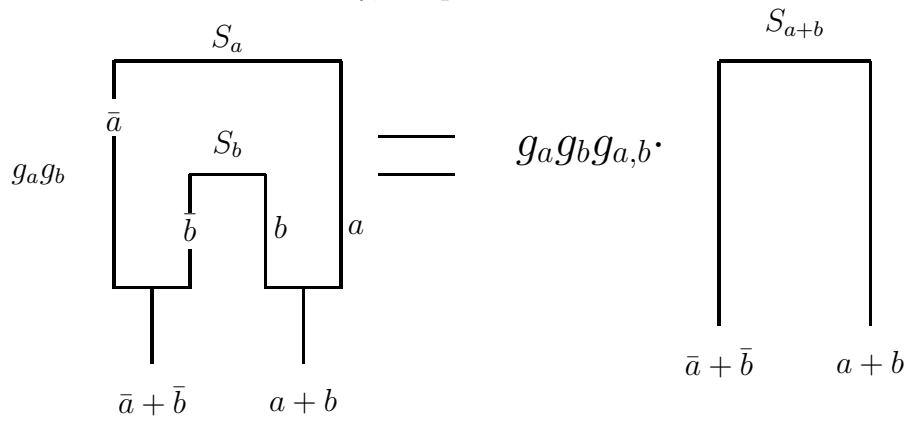
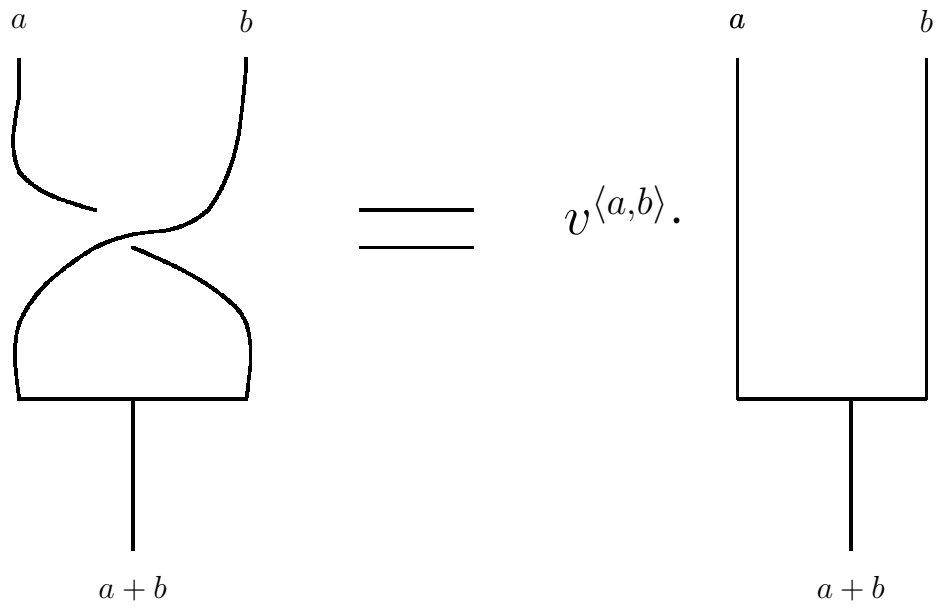

Morphism $tr_{a,b}^c$, §21.1

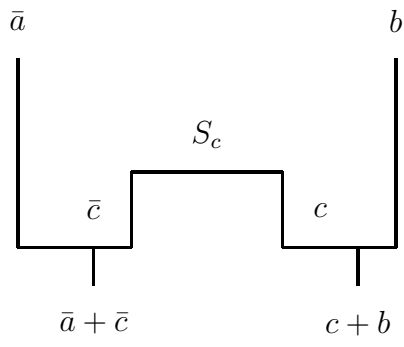

Transitivity of tr , Prop.21.3

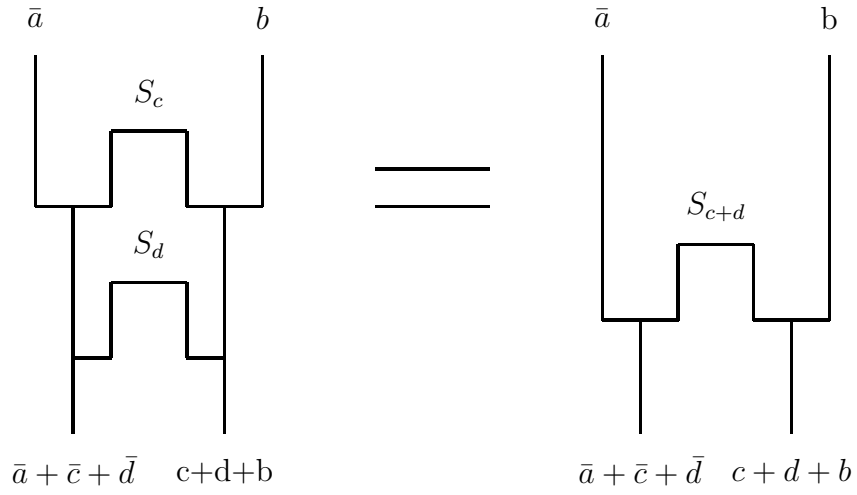

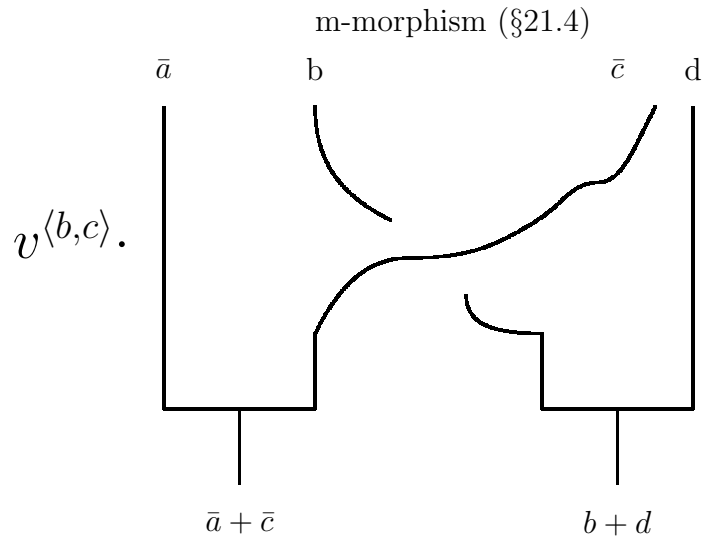

Left compatibility of m- and tr-morphisms, Prop.21.6

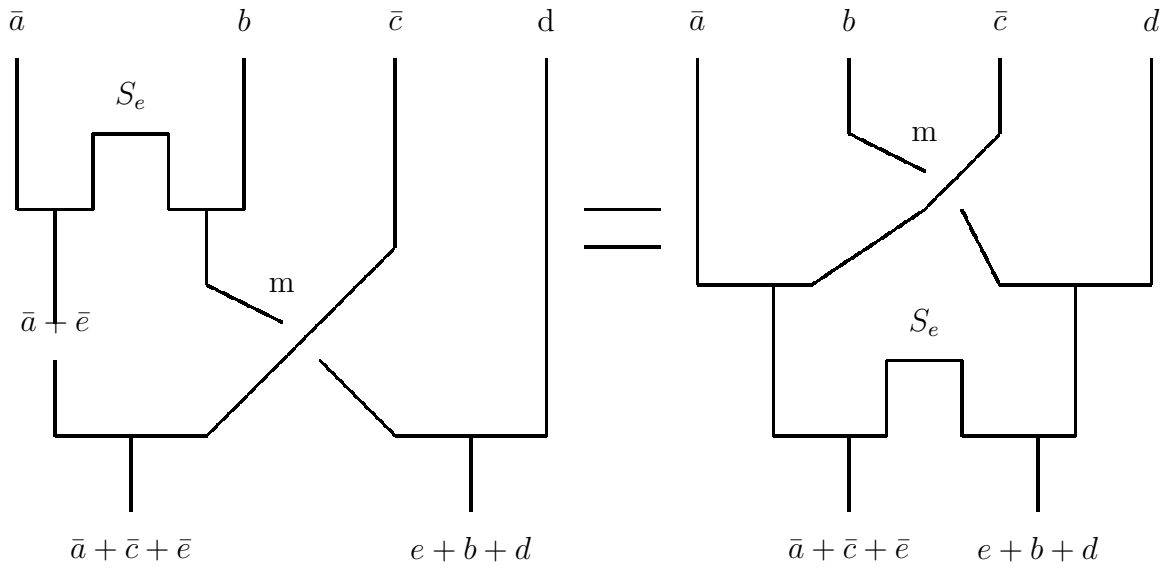

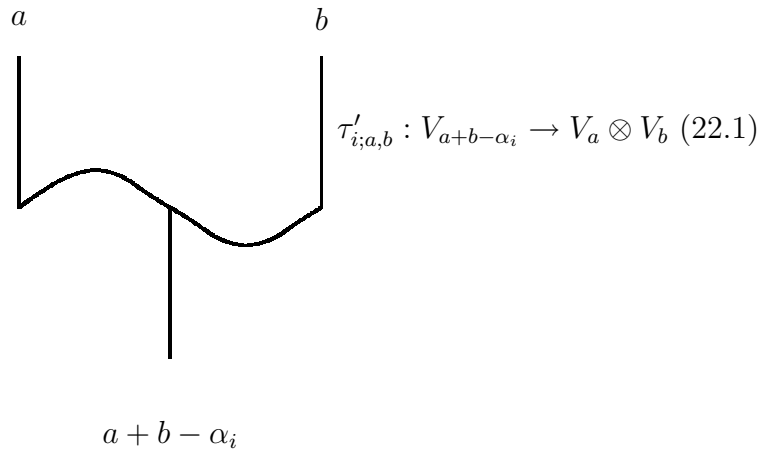
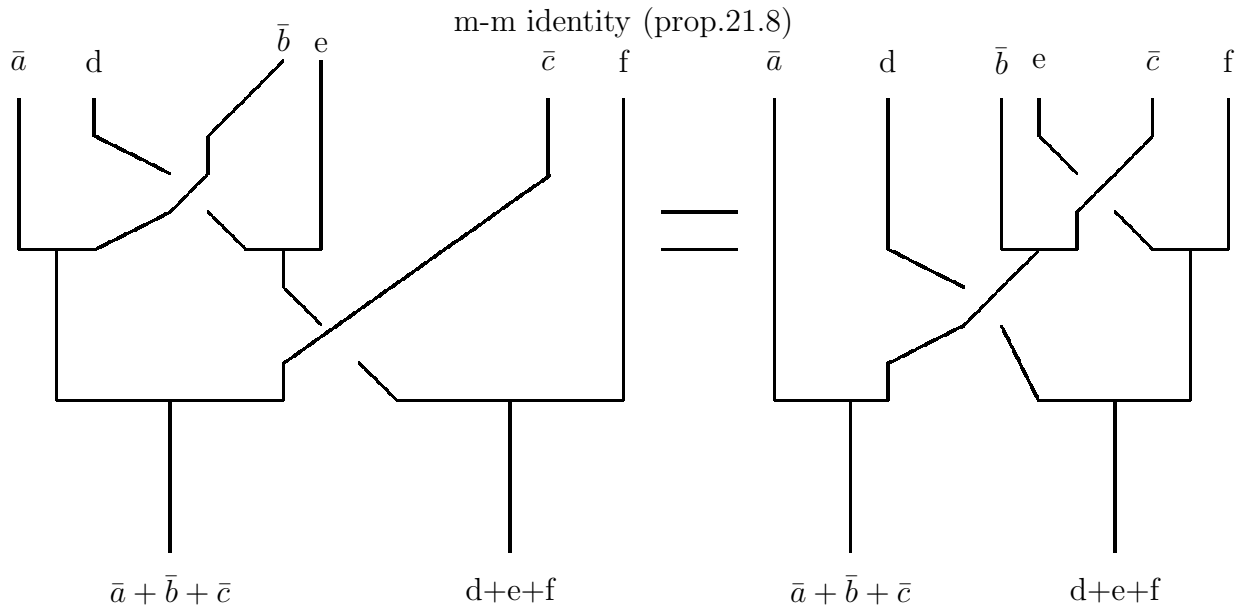

$\tau - S$ -identity, §23.7

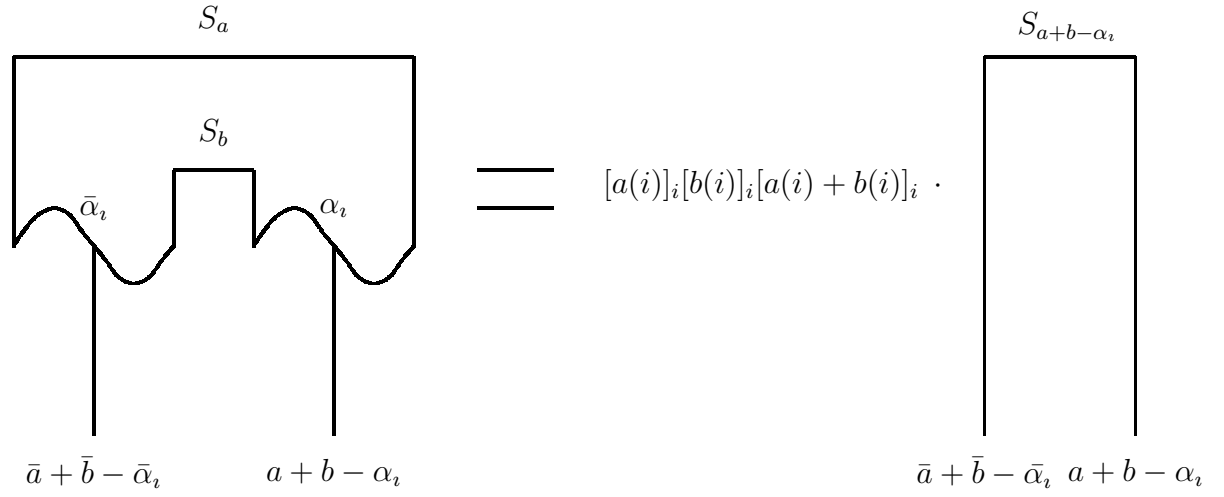

τT -identity (1), Prop.22.6

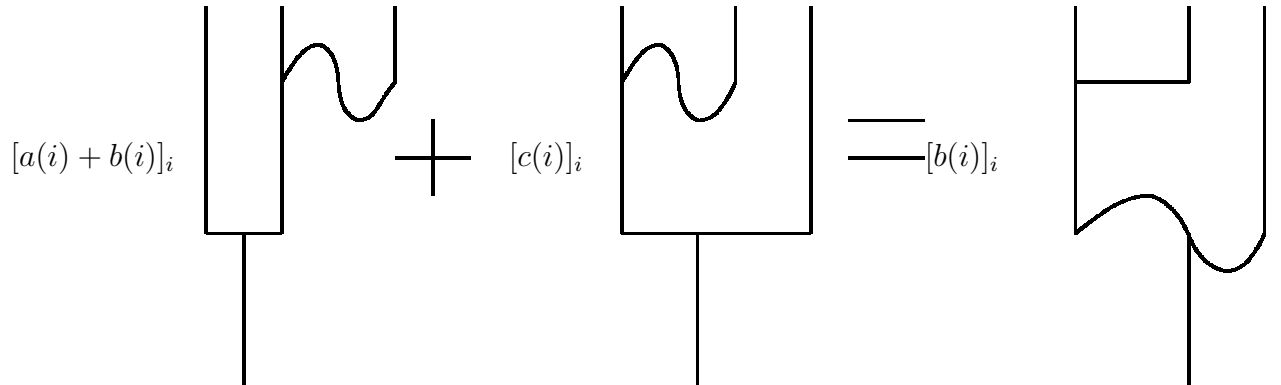

$\tau - T$ -identity (2), Prop.22.6

$[a(i)]_i + [b(i) + c(i)]_i = [b(i)]_i$

$\tau - T$ -identity (3), Prop.22.6

$[b(i) + c(i)]_i - [c(i)]_i = [a(i) + b(i) + c(i)]_i$

$\tau - T$ -identity (4), Prop. 22.6

$$-[a(i)]_i \text{ (diagram)} + [a(i) + b(i)]_i \text{ (diagram)} = [a(i) + b(i) + c(i)]_i \text{ (diagram)}$$

A relation for τ , T and C , Cor. 22.9

$$\begin{array}{c} a \quad b \quad c \\ \text{(diagram)} \\ a + b + c - \alpha_i \end{array} = v^{\langle c, b \rangle} \cdot \text{(diagram)} + v_i^{-a(i)} \cdot \text{(diagram)}$$

Morphism $\Phi_{i,a,b}^c$, §23.1

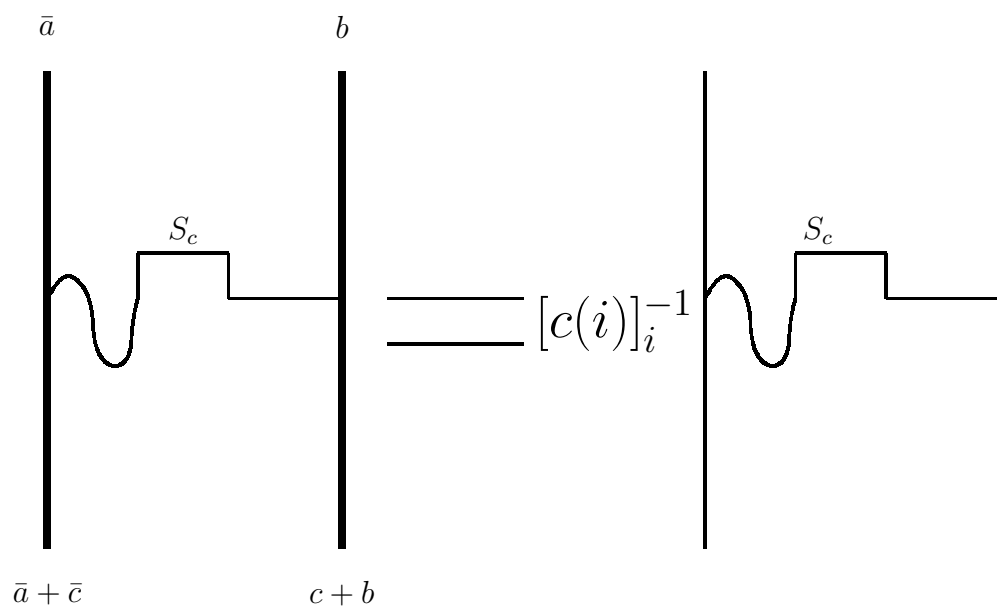

Morphism $\Psi_{i,a,b}^c$, §23.1

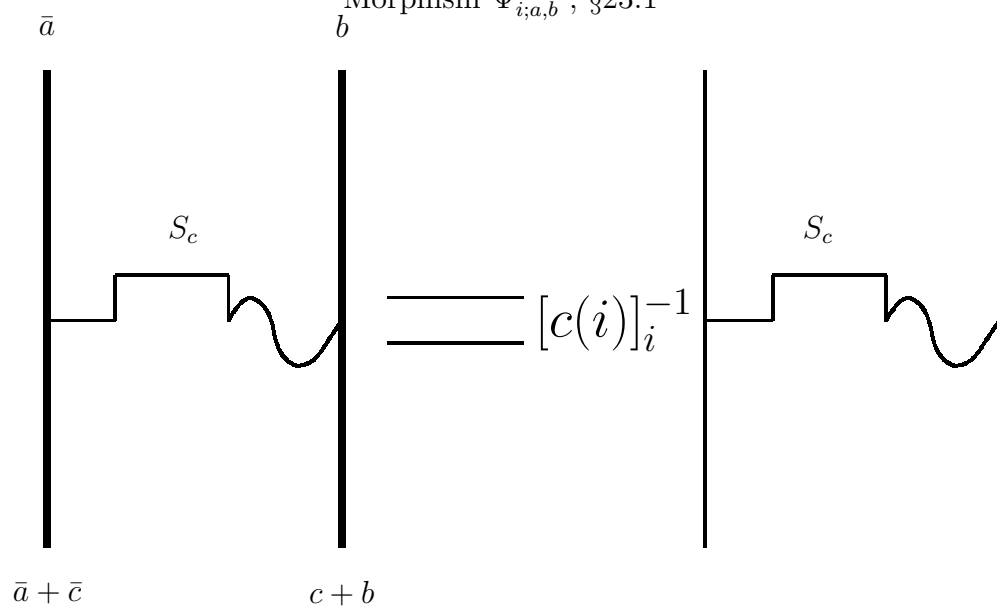

$\Phi - tr$ -identity (1) , Prop.23.2(a)

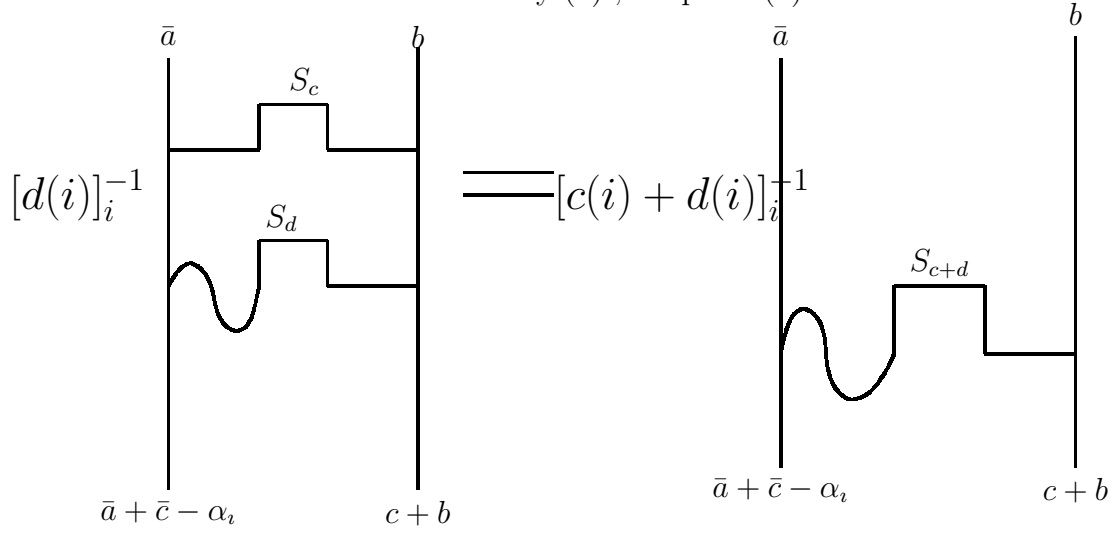

$\Phi - tr$ -identity (2) , Prop.23.2(b)

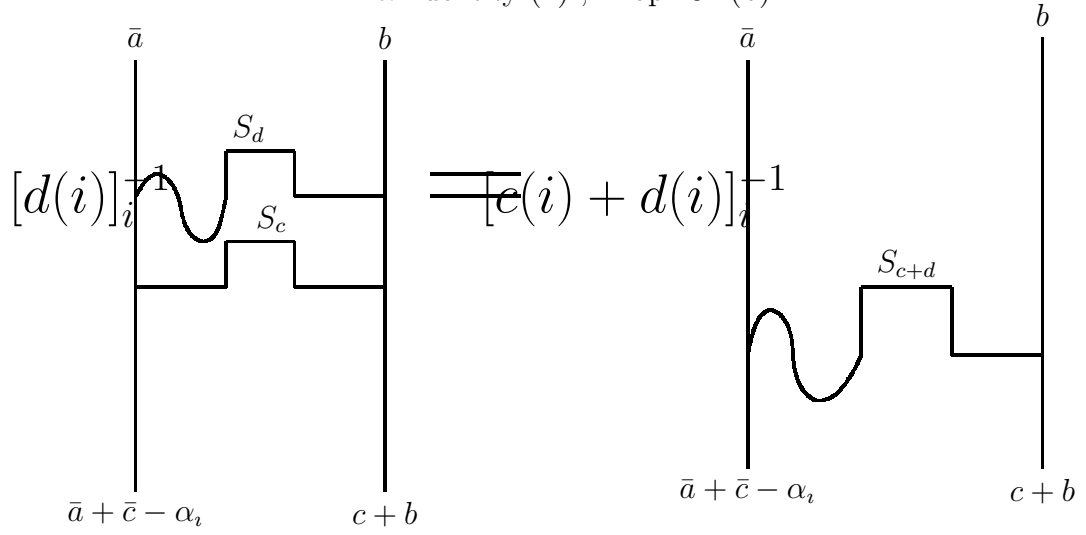

$$V^{(a,b)} := \text{Hom}_{\mathcal{D}}(V_{\bar{a}} \otimes V_b, V), \text{ §25.1}$$

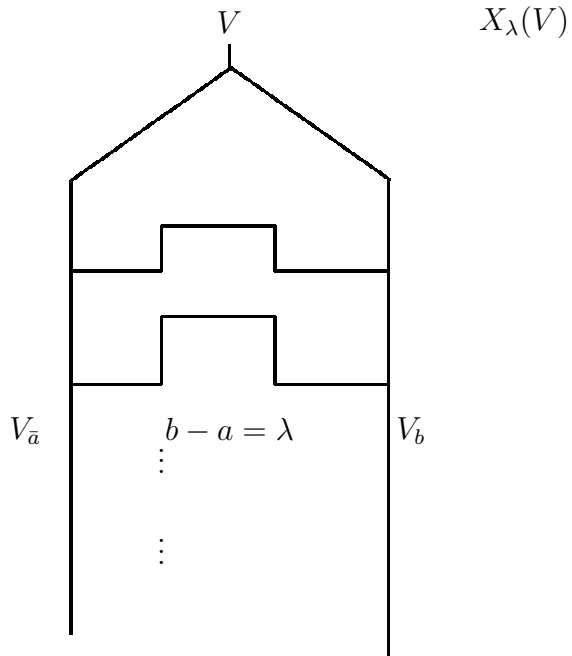
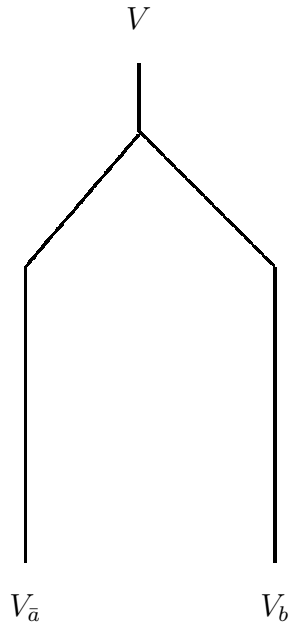

The tensor product $X_\lambda(V) \otimes X_{\lambda'}(V') \rightarrow X_{\lambda+\lambda'}(V \otimes V')$, 25.5(a)

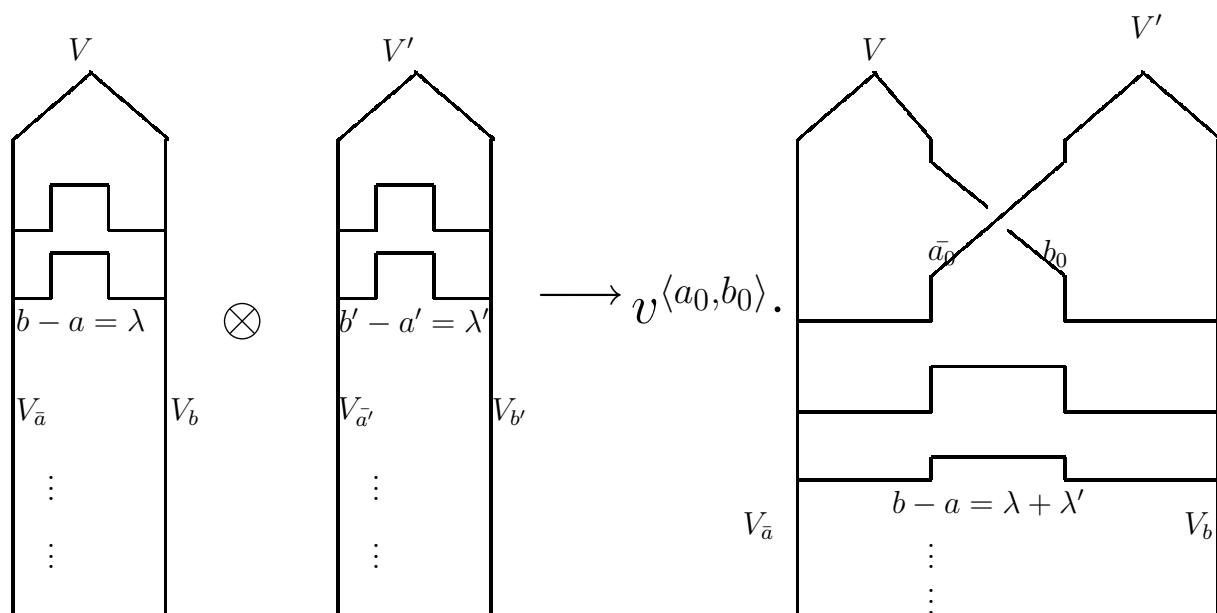

Associativity of the functor X , Prop.25.8

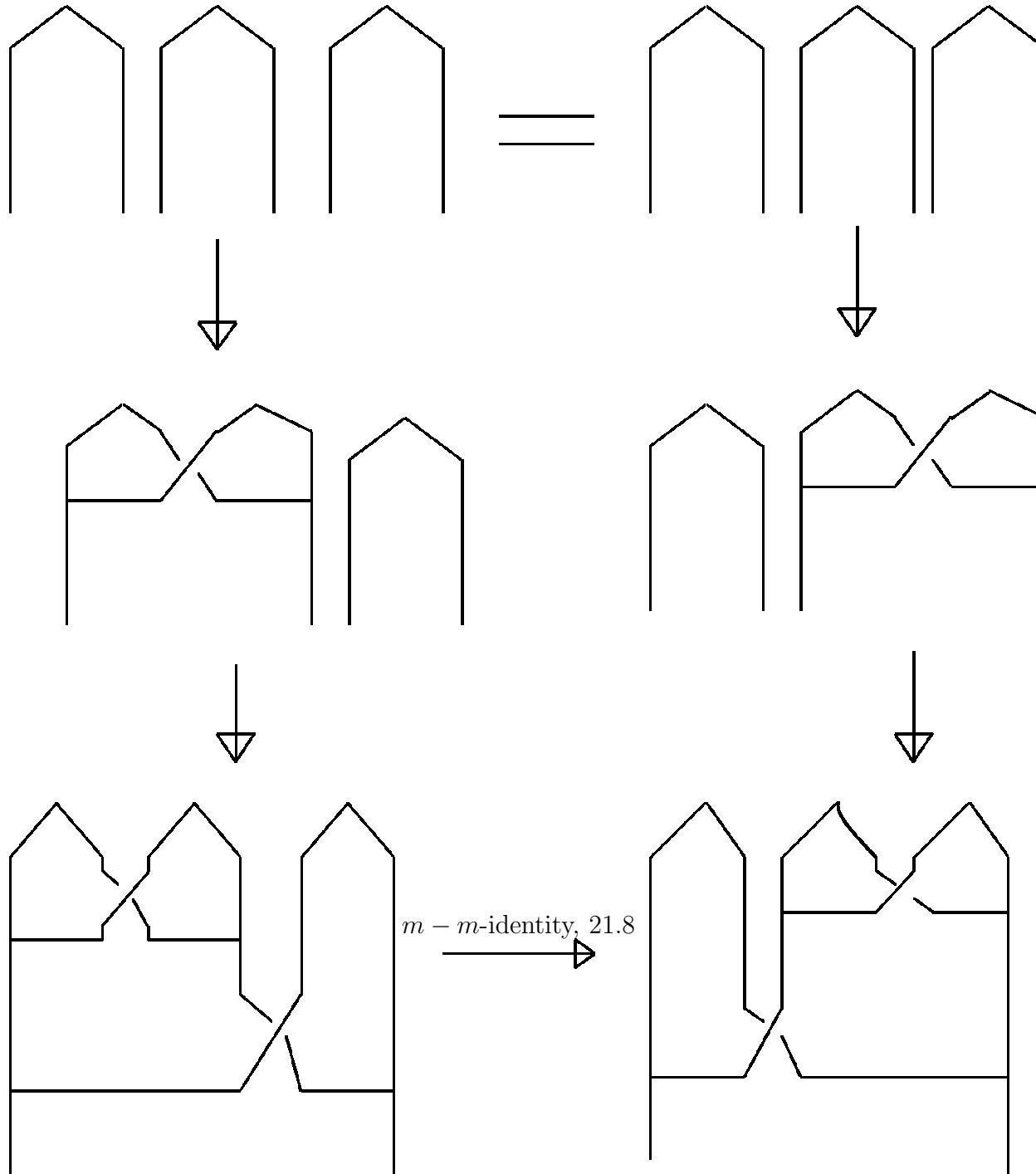

The morphism E_i , representing a quantum group element

